

CONTRACT AND SPECIFICATIONS

For

**Street Reconstruction
East Blackberry Street
Jonestown Borough, Lebanon County**

Contract C-5-22-JB

May, 2022

**REDEVELOPMENT AUTHORITY OF THE COUNTY OF LEBANON
137 W Penn Avenue
Cleona, Pennsylvania**

**Community Development Block Grant
Small Communities Program**

Administered Through:

**The Redevelopment Authority
of the County of Lebanon
Karen Raugh, Executive Director
137 West Penn Avenue
Cleona, PA 17042
717-274-1401**

STOP

EXTREMELY IMPORTANT

Before proceeding further you **MUST** complete this form and return it via e-mail to the Redevelopment Authority at the address listed below. ALL vendors who obtain these plans **MUST** register with the Redevelopment Authority.

IF YOU DO NOT COMPLETE THIS FORM AND RETURN IT TO THE REDEVELOPMENT AUTHORITY YOUR BID WILL NOT BE CONSIDERED.

Company Name: _____

Company Address: _____

Contact Name: _____

Contact Telephone: _____ Contact Fax: _____

Contact Email: _____

Project Name: C-5-22-JB

RETURN THIS FORM TO: dlyons@lebanoncountyredevelopment.com

Once this form is received by the Redevelopment Authority you will be added to the list of firms who have received the RFP and who are authorized to submit a bid for this solicitation. You will receive a return e-mail from the Redevelopment Authority acknowledging receipt of your registration.

If you have any questions please contact the Redevelopment Authority staff member referenced in the solicitation.

FOR AUTHORITY USE ONLY

The Redevelopment Authority hereby acknowledges receipt of your registration for the above referenced solicitation.

Received by: _____

Date Received: _____

Contract Documents for Site Preparation

Table of Contents

INVITATION FOR BIDS 1

Instruction to Bidders..... 3

1. Use of Separate Bid Forms 3

2. Interpretations or Addenda..... 3

3. Inspection of Site 3

4. Alternative Bids 3

5. Bids 3

6. Bid Guaranty 4

7. Collusive Agreements 4

8. Statement of Bidder’s Qualifications 4

9. Unit Prices 5

10. Corrections 5

11. Time for Receiving Bids 5

12. Opening of Bids 5

13. Withdrawal of Bids 5

14. Award of Contract: Rejection of Bids..... 5

15. Execution of Agreement: Performance and Payment Bond..... 6

16. Wages and Salaries 6

17. Equal Employment Opportunity 7

18. Employment of Lower Income Residents and Business Utilization..... 7

19. Minority and Women’s Business Enterprises 7

PROPOSAL 12

NONCOLLUSION AFFIDAVIT OF PRIME BIDDER 14

BID BOND 15

STATEMENT OF BIDDER'S QUALIFICATIONS..... 17

MBE/WBE SUBCONTRACTOR AND SUPPLIER 19

SOLICITATION AND COMMITMENT FORM 19

AGREEMENT FOR SITE PREPARATION 22

CORPORATE CERTIFICATION..... 24

STIPULATION AGAINST LIENS 25

INSTRUCTIONS FOR PREPARATION OF PERFORMANCE BOND, LABOR AND MATERIALMEN'S BONDS, AND, IF REQUIRED,..... 26

HIGHWAY OCCUPANCY PERFORMANCE BOND..... 26

PERFORMANCE BOND..... 28

LABOR AND MATERIALMEN'S BOND..... 30

HIGHWAY OCCUPANCY PERFORMANCE BOND..... 32

AFFIRMATIVE ACTION PLAN FOR UTILIZATION OF MINORITY BUSINESS 34

AFFIRMATIVE ACTION PLAN FOR BUSINESS UTILIZATION **Error! Bookmark not defined.**

SECTION 3..... **Error! Bookmark not defined.**

CERTIFICATION OF COMPLIANCE **Error! Bookmark not defined.**

SECTION 3..... **Error! Bookmark not defined.**

GENERAL CONDITIONS 36

PART I..... 36

101. DEFINITIONS..... 36

102. SUPERINTENDENCE BY CONTRACTOR 36

103. SUBCONTRACTS 37

104. Other Contracts 39

105. Fitting and Coordination of the Work..... 39

106. Mutual Responsibility of Contractors 39

107.	Progress Schedule	39
108.	Payments to Contractor.....	39
109.	Changes in the Work.....	41
110.	Claims for Extra Cost.....	42
111.	Termination – Delays – Liquidated Damages.....	42
112.	Assignment or Novation	43
113.	Disputes.....	43
114.	Technical Specifications and Drawings.....	44
115.	Shop Drawings.....	44
116.	Requests for Supplementary Information	44
117.	Materials and Workmanship	45
118.	Samples, Certificates, and Tests	45
119.	Permits and Codes.....	46
120.	Care of Work.....	48
121.	Accident Prevention.....	48
122.	Sanitary Facilities.....	49
123.	Use of Premises.....	49
124.	Removal of Debris, Cleaning, Etc.	49
125.	Inspection.....	49
126.	Review by Local Public Agency.....	50
127.	Final Inspection.....	51
128.	Deduction for Uncorrected Work	51
129.	Insurance	51
130.	Patents	52
131.	Warranty of Title.....	52
132.	General Guaranty	52
	GENERAL CONDITIONS	54
	PART II.....	54
	FEDERAL REQUIREMENTS.....	54
I.	Title VI of the Civil Rights Act of 1964 (P.L. 88-352) as stated in 24 CFR 570.496.	54
II.	Executive Order 11063, as amended.....	54
III.	Executive Order 11246.....	54
IV.	CONTRACT WORK HOURS AND SAFETY STANDARDS ACT (40 U.S.C. 327 ET SEQ.).....	61
V.	FEDERAL LABOR STANDARDS PROVISIONS.....	61
VI.	Section 3 of the Housing and Urban Development Act of 1968 (12 U.S.C. 1701 u).	70
VII.	Lead Based Paint Requirements.	71
VIII.	Clean Air and Clean Water Acts.	71
IX.	Energy Conservation Provisions.	73
X.	Section 109 of the Housing and Community Development Act of 1974.....	73
XI.	Executive Order 11625 - Minority Business Enterprise, and Executive Order 12138 -- Women’s Business Enterprise.....	73
XII.	Age Discrimination Act of 1975.....	73
XIII.	Section 504 Handicapped (if \$2,500 or over).	74
XIV.	Pennsylvania Steel Products Procurement Act (No. 178-3).	75
XV.	Pennsylvania Human Relations Act, as amended.	75
	NONDISCRIMINATION/SEXUAL HARASSMENT CLAUSE	77
	GENERAL SPECIFICATIONS	79
	SPECIAL CONDITIONS FOR SITE PREPARATION	79
	PART III	79
301.	PROJECT SITE	79
302.	TIME FOR COMPLETION	79
303.	LIQUIDATED DAMAGES	79
304.	RESPONSIBILITIES OF CONTRACTOR	79
305.	COMMUNICATIONS	79

306.	Signs.....	80
307.	Job Offices	80
308.	Partial Use of Site Improvements	80
309.	Work By Others	81
310.	Contract Documents and Drawings	81
311.	Other Special Conditions	81
	CONTRACT CHANGE ORDER.....	83
	CHANGE ORDER - TIME ONLY INVOLVED.....	85
	CONTRACTOR'S CERTIFICATE AND RELEASE	87

ATTACHMENTS

1. Construction Drawings
2. Technical Specifications
3. Highway Occupancy Permit (held by Dqtqw j)
4. MBE/WBE Requirements
5. Federal Prevailing Wage Determination
6. Bid Submission Packet

INVITATION FOR BIDS

The Redevelopment Authority of the County of Lebanon will receive bids for Stormwater Improvements in Avon, South Lebanon Township and Street Improvements on East Blackberry Street in Jonestown Borough, Lebanon County, Construction Contract Numbers C-5-22-SLT and C-5-22-JB, respectively, until 2:00 p.m. prevailing time, on the 31st day of May, 2022, at the offices of the Authority at 137 W Penn Avenue, Cleona, PA 17042. All bids will be publicly opened and read aloud at that time.

Bids are invited for Contract Numbers:

C-5-22-SLT Avon Stormwater Improvements, South Lebanon Township
C-5-22-JB Street Reconstruction, East Blackberry Street, Jonestown Borough

All contracts will be bid and awarded independently; bidders may bid on one or both of the contracts as they choose.

A pre-bid conference will be held for the Avon Stormwater Improvements project on Thursday, May 19, 2022 at 8am at the South Lebanon Township building at 1800 S 5th Avenue, Lebanon, PA 17042.

Contract documents, including Drawings and Technical Specifications, are available free of charge online at www.lebanoncountyredevelopment.com.

When downloading online specifications, prospective bidders will be required to register with the Authority by e-mail per the instructions with the bid specifications. Addenda, if any, will be issued only to those persons whose name and address are on record with the owner as having obtained the Contract Documents.

A Bid Bond, in the form provided in the documents, in an amount equal to ten percent (10%) of the bid shall be submitted with each bid.

Attention of the bidders is called to the fact that the Contract Documents contain information pertaining to: Davis Bacon Federal Prevailing Wage Rates, Non Discrimination Requirements, Equal Opportunity goals, and MBE/WBE requirements.

The owner reserves the right to reject any or all bids or to waive any informality in the bidding.

Bids may be held by the owner for a period not to exceed sixty (60) days from the date of opening for the purpose of reviewing the bids and investigating the qualifications of bidders prior to awarding the contract.

Karen Raugh
Executive Director

THIS PAGE INTENTIONALLY LEFT BLANK

INSTRUCTION TO BIDDERS

1. USE OF SEPARATE BID FORMS

These Contract Documents include a complete set of bidding and Contract forms which are for the convenience of bidders and are not to be detached from the Contract Documents, filled out, or executed. Separate copies of Bid Forms are furnished for that purpose.

2. INTERPRETATIONS OR ADDENDA

No oral interpretation will be made to any Bidder as to the meaning of the Contract Documents or any part thereof. Every request for such an interpretation shall be made in writing to the Local Public Agency. Any inquiry received seven or more days prior to the date fixed for opening of Bids will be given consideration. Every interpretation made to a Bidder will be in the form of an Addendum to the Contract Documents and, when issued, will be on file in the office of the Local Public Agency and the office of the Engineer at least five days before Bids are opened. In addition, all Addenda will be mailed to each person holding Contract Documents, but it shall be the Bidder's responsibility to make inquiry as to the Addenda issued. All such Addenda shall become part of the Contract and all Bidders shall be bound by such Addenda, whether or not received by the Bidders.

3. INSPECTION OF SITE

Each Bidder should visit the site of the proposed work and fully acquaint himself with the existing conditions there relating to construction and labor, and should fully inform himself as to the facilities involved, the difficulties and restrictions attending the performance of the Contract. The Bidder should thoroughly examine and familiarize himself with the Drawings, Technical Specifications, and all other Contract Documents. The Contractor by the execution of the Contract shall in no way be relieved of any obligation under it due to his failure to receive or examine any form or legal instrument or to visit the site and acquaint himself with the conditions there existing, and the Local Public Agency will be justified in rejecting any claim based on facts regarding which he should have been on notice as a result thereof.

4. ALTERNATIVE BIDS

No alternative bids will be considered unless alternative bids are specifically requested.

5. BIDS

- a. All Bids must be submitted on forms supplied by the Local Public Agency and shall be subject to all requirements of the Contract Documents, including the Drawings, and these INSTRUCTIONS TO BIDDERS. All Bids must be regular in every respect and no interlineations, excisions or special conditions shall be made or included in the Bid Form by the Bidder.
- b. Bid Documents including the Bid, the Bid Guaranty, the Non Collusion Affidavit, the Statement of Bidder's Qualifications (if requested) and all addenda, if any, shall be enclosed in an envelope. The envelope should be such to provide adequate security for the bidding documents. It shall be sealed and clearly labeled with the words ("Site Preparation Bid Documents"), project number, name of Bidder, and date and time of bid opening in order to guard against premature opening of the bid.
- c. The Local Public Agency may consider irregular any Bid on which there is an alteration of or departure from the Bid Form hereto attached and at its option may reject the same.

- d. When the Contract is awarded, it will be awarded by the Local Public Agency to a responsible Bidder on the basis of the lowest Bid and the selected Alternative Bid items, if any. The Contract will require the completion of the work according to the Contract Documents.

6. BID GUARANTY

- a. The bid must be accompanied by a Bid Guaranty which shall not be less than 10 percent (10%) of the amount of the Bid. At the option of the Bidder, the Guaranty may be a certified check, bank draft, negotiable U.S. Government Bonds (at par value), or a Bid bond in the form attached. The Bid bond shall be secured by a Guaranty or a surety company listed in the latest issue of U.S. Treasury Circular 570. The amount of such Bid bond shall be within the maximum amount specified for such Company in said Circular 570. No Bid will be considered unless it is accompanied by the required Guaranty. Certified check or bank draft must be made payable to the order of the Redevelopment Authority of the County of Lebanon. Cash deposits will not be accepted. The Bid Guaranty shall ensure the execution of the Agreement and the furnishing of the surety bond or bonds by the successful Bidder, all as required by the Contract Documents.
- b. Revised Bids submitted before the opening of Bids, whether forwarded by mail or telegram, if representing an increase in excess of two percent (2%) of the original Bid, must have the Bid Guaranty adjusted accordingly; otherwise the Bid will not be considered.
- c. Certified checks or bank drafts, or the amount thereof, Bid bonds, and negotiable U.S. Government bonds of unsuccessful Bidders will be returned as soon as practical after the opening of the Bids.

7. COLLUSIVE AGREEMENTS

- a. Each Bidder submitting a Bid to the Local Public Agency for any portion of the work contemplated by the documents on which bidding is based shall execute and attach thereto, an affidavit substantially in the form herein provided, to the effect that he has not colluded with any other person, firm, or corporation in regard to any Bid submitted.
- b. Before executing any subcontract the successful Bidder shall submit the name of any proposed subcontractor for prior approval and an affidavit substantially in the form provided in Section 103, SUBCONTRACTS UNDER GENERAL CONDITIONS, PART I.

8. STATEMENT OF BIDDER'S QUALIFICATIONS

Each Bidder shall submit on the form furnished for that purpose (a copy of which is included in the Contract Documents), a statement of the Bidder's qualifications, his experience record in constructing the type of Improvements embraced in the Site Preparation, and his organization and equipment available for the work contemplated; and, when specifically requested by the Local Public Agency, a detailed financial statement. The Local Public Agency shall have the right to take such steps as it deems necessary to determine the ability of the Bidder to perform his obligations under the Contract, and the Bidder shall furnish the Local Public Agency all such information and data for this purpose as it may request. The right is reserved to reject any Bid where an investigation of the available evidence or information does not satisfy the Local Public Agency that the Bidder is qualified to carry out properly the terms of the Contract.

9. UNIT PRICES

The unit price for each of the several items in the proposal of each Bidder shall include its prorata share of overhead so that the sum of the products obtained by multiplying the quantity shown for each item by the unit price Bid represents the Total Bid. Any Bid not conforming to this requirement may be rejected as informal. The special attention of all Bidders is called to this provision, for should conditions make it necessary to revise the quantities, no limit will be fixed for such increased or decreased quantities nor extra compensation allowed, provided the net monetary value of all such additive and subtractive changes in quantities of such items of work (i.e., difference in cost) shall not increase or decrease the original contract price by more than twenty-five (25) percent, except for work not covered in the Drawings and Technical Specifications as provided for in the Section - CHANGES IN THE WORK UNDER GENERAL CONDITIONS, PART I.

10. CORRECTIONS

Erasures or other changes in the Bids must be explained or noted over the signature of the Bidder, and initialed.

11. TIME FOR RECEIVING BIDS

- a. Bids received prior to the advertised hour of opening will be securely kept, sealed. The officer whose duty it is to open them will decide when the specified time has arrived, and no Bid received thereafter will be considered; except that when a Bid arrives by mail after the time fixed for opening, but before the reading of all other Bids is completed, and it is shown to the satisfaction of the Local Public Agency that the non-arrival on time was due solely to delay in the mails for which the Bidder was not responsible, such Bid will be received and considered.
- b. Bidders are cautioned that, while telegraphic modifications of Bids may be received as provided above, such modifications, if not explicit and if in any sense subject to misinterpretation, shall make the Bid so modified or amended, subject to rejection.

12. OPENING OF BIDS

At the time and place fixed for the opening of Bids, the Local Public Agency will cause to be opened and publicly read aloud every Bid received within the time set for receiving Bids, irrespective of any irregularities therein. Bidders and other persons properly interested may be present, in person or by representative.

13. WITHDRAWAL OF BIDS

Bids may be withdrawn on written or telegraphic request dispatched by the Bidder in time for delivery in the normal course of business to the time fixed for opening; provided, that written confirmation of any telegraphic withdrawal over the signature of the Bidder is placed in the mail and postmarked prior to the time set for Bid opening. The Bid Guaranty of any Bidder withdrawing his Bid in accordance with the foregoing conditions will be returned promptly.

14. AWARD OF CONTRACT: REJECTION OF BIDS

- a. The Contract will be awarded to the responsible Bidder submitting the lowest bid complying with the conditions of the Invitation for Bids. The Bidder to whom the award is made will be notified at the earliest possible date. The Local Public Agency, however, reserves the right to reject any and all Bids and to waive any informality in Bids received whenever such rejection or waiver is in its interest.

- b. The Local Public Agency reserves the right to consider as unqualified to do the work of general construction any Bidder who does not habitually perform with his own forces the major portions of the work involved in construction of the Improvements embraced in this Site Preparation Contract.

15. EXECUTION OF AGREEMENT: PERFORMANCE AND PAYMENT BOND

- a. Subsequent to the award and within ten (10) days after the prescribed forms are presented for signature, the successful Bidder shall execute and deliver to the Local Public Agency an Agreement in the form included in the Contract Documents in such number of copies as the Local Public Agency may require. The Owner retains the right to issue extensions to the said ten (10) day filing time as it deems to be in its best interest. When extensions are granted to the time allotted to the Contractor for return of executed Contract Documents, the contract time for completion, as indicated *Special Conditions for Site Preparation – Part III*, shall commence no later than 30 days following issuance of the Notice of Award.
- b. Having satisfied all conditions of award as set forth elsewhere in these documents, the successful Bidder shall, within the period specified in paragraph "a" above, furnish a surety bond in a penal sum not less than the amount of the Contract as awarded, as security for the faithful performance of the Contract, and for the payment of all persons, firms or corporations to whom the contractor may become legally indebted for labor, materials, tools, equipment, or services of any nature including utility and transportation services, employed or used by him in performing the work. Such bond shall be in the same form as that included in the Contract Documents and shall bear the same date as, or a date subsequent to, that of the Agreement. The current power of attorney for the person who signs for any surety company shall be attached to such bond. This bond shall be signed by a Guaranty or surety company listed in the latest issue of the U.S. Treasury Circular 570 and the penal sum shall be within the maximum specified for such company in said Circular 570.
- b.1 If any of the work of this contract is to be performed within the right-of-way of the Pennsylvania Department of Transportation, an additional performance bond will be required to obtain the necessary Highway Occupancy Permit. Such performance bond shall be provided by the Contractor on the form provided for that purpose, as shown on pages 23-a. and 23-b. following, and shall bind the Contractor and the relevant Permittee collectively as "Principal" to the Commonwealth of Pennsylvania as "Obligee" in an amount determined by the Pennsylvania Department of Transportation. Such amount is based upon the number of lineal feet of contract work located within the State right-of-way which is in the paved road-way (\$20.00 per l.f.), in a paved or improved shoulder (\$15.00 per l.f.) and off of any paved or improved surface (\$10.00 per l.f.).
- c. The failure of the successful Bidder to execute such Agreement and to supply the required bond or bonds within ten days after the prescribed forms are presented for signature, or within such extended period as the Local Public Agency may grant, based upon reasons determined sufficient by the Local Public Agency, shall constitute a default, and the Local Public Agency may either award the Contract to the next lowest responsible Bidder or readvertise for Bids, and may charge against the Bidder the difference between the amount of the Bid and the amount for which a Contract for the work is subsequently executed, irrespective of whether the amount thus due exceeds the amount of the Bid bond. If a more favorable Bid is received by readvertising, the defaulting Bidder shall have no claim against the Local Public Agency for a refund.

16. WAGES AND SALARIES

- a. Attention of Bidders is particularly called to the requirement concerning the payment of not less than the prevailing wage and salary rates specified in the Contract Documents and the conditions of

employment with respect to certain categories and classifications of employees. (See GENERAL CONDITIONS, PART II.)

- b. The rates of pay set forth under GENERAL CONDITIONS, PART II, are the minima to be paid during the life of the Contract. It is therefore the responsibility of Bidders to inform themselves as to local labor conditions, such as the length of work day and work week, overtime compensation, health and welfare contributions, labor supply and prospective changes or adjustments of rates.

17. EQUAL EMPLOYMENT OPPORTUNITY

Attention of Bidders is particularly called to the requirement for ensuring that employees and applicants for employment are not discriminated against because of their race, creed, color, or national origin. A goal for participation in each trade in all Federal and Federally-assisted construction contracts of 6.9% for females has been set nationally and of 4.8% for minorities has been set for the county. (See GENERAL CONDITIONS, PART III, SECTION 301 and 308.)

18. ~~EMPLOYMENT OF LOWER INCOME RESIDENTS AND BUSINESS UTILIZATION~~ [NOT APPLICABLE TO THIS PROJECT]

- a. Attention of Bidders is called to the special requirements of the "Section 3 Clause" of 24 CFR 135.20, which require that to the greatest extent feasible opportunities for training and employment be given lower income residents of the covered area and contracts for work in connection with the project be awarded to business concerns which are located in, or owned, in substantial part, by persons residing in the covered area. (See GENERAL CONDITIONS, PART III, SECTION 306.)
- b. Contractors must utilize, to the greatest extent possible, minority business concerns located within the locality. (See GENERAL CONDITIONS, PART III, SECTION 307.)

19. MINORITY AND WOMEN'S BUSINESS ENTERPRISES

To the greatest extent feasible, contractors shall utilize minority and women's business enterprises when subcontracting and obtaining materials and supplies.

A. PARTICIPATION LEVEL

- (1) The Local Public Agency has established minimum participation levels (MPLs) at 5% for minority business enterprises (MBE) and 3% for women's business enterprises (WBE) for this project, to be used solely as a threshold in determining Bidder responsibility. A Bidder will not be rejected as not responsible solely because it fails to reach the MPLs. To determine the participation level which has been reached, a Bidder may divide the total dollar amount of the commitments by the total dollar amount of the Bidder's bid.
- (2) MBE/WBE subcontracts and manufacturers will be credited toward the minimum level at 100%. Stocking suppliers are credited at 100%. Non-stocking suppliers which are commonly and ordinarily the custom in the industry and a part of the industry's trade practices are credited at 100%; non-stocking suppliers which are not commonly and ordinarily the custom in the industry nor a part of the industry's trade practice are not credited. A firm which is both an MBE and WBE will only receive credit toward MPLs as either an MBE or WBE, but not both. Bidders must indicate on Form DCED-CCD-286, MBE/WBE Contact/Solicitation and Commitment Statement whether the firm is being listed as either an MBE or a WBE.

- (3) An MBE/WBE firm who is the prime Bidder on a project will receive no MPL credit for its own work effort for services provided. MBEs/WBEs bidding as prime proposer must solicit other certified MBE/WBE participation for materials and/or supplies.
- (4) MBE/WBE subcontractors must perform at least seventy-five percent (75%) of the cost of the subcontract, not including the cost of materials, with its own employees.

B. RESPONSIVENESS

MBE/WBE BIDDING REQUIREMENTS -

ONLY RESPONSIVE BIDS WILL BE CONSIDERED. TO BE RESPONSIVE:

1. You the bidder **must** submit a Form DCED-CCD-286, completed according to the instructions that are provided with it.
2. You **must** make a good faith effort to give MBE and WBE firms an opportunity to participate in the work of this contract. To the extent such firms offer to provide materials or services needed for the work, at prices which are advantageous to you, you must make (and keep) a commitment to obtain those materials/services. Failure to make a good faith effort will result in a determination that your bid is not responsive. (Failure to make and keep such commitments will be considered evidence of discriminatory practices.)
3. At a minimum, you **must** contact the firms identified in the listing provided as a part of these contract documents for quotes on the items or services you will need.
 - a. If you receive a satisfactory quote from a listed supplier and commit to it, you do not need to contact other suppliers for the same items/services.
 - b. If you get a quote that is higher than you must pay from some other source, you do not need to accept the higher quote, but you must document that the quote is higher by showing the quote and showing the source and price you will use. Include the date and time of contact in your documentation.
 - c. In documenting quotes you commit to, and those you reject as being too high, you must show unit prices, multiplied by your best estimate of the quantities of goods and/or services you expect to use. This information is essential to a determination that Minimum Levels of Participation have been achieved, and is needed for verification during construction that commitments made are being kept. It is expected that there may be variations in the quantity estimates you use for some goods/services from final actual quantities. *Minor variations will not be questioned. Significant changes, however, will require documentation that this difference resulted from changes in the work of the contract--not motivated by an intent to reduce the committed amount of MBE/WBE participation.*
 - d. If you make contact with a listed supplier but do not receive a quote, document this by date and time of contract.
 - e. If you attempt to make a contact without response -- for example, "phone disconnected"; "out of business"; "moved, no forwarding address" -- document the attempt, again using date and time. It is important that the Redevelopment Authority be made aware of any non-response of this type so that the lists provided to us by the State can be kept up to date.

4. If you have obtained satisfactory quotes from one or more of the listed firms and made commitments to them, **and**, if the total of those commitments equal or exceed the “Minimum Levels of Participation” (5% MBE and 3% WBE), your bid will be deemed responsive.
5. You may seek to achieve the minimum levels of participation using firms other than those in the list provided. If so, you must also document that the firm you use is a currently certified MBE or WBE. If that certification is not by the Commonwealth Minority and Women Business Enterprise Office, such firms may be considered but you (and they) must identify who has certified them. Acceptance of certification by other than the Commonwealth Minority and Women Business Enterprise Office will be at the discretion of the Authority.
6. If you have made a good faith effort (and properly documented that effort in your DCED-CCD-286 with such supplemental documentation as needed) failure to achieve the Minimum Level of Participation will not result in a determination of non-responsiveness.
7. If you have evidence that a quote given you by a MBE/WBE is not a bona fide attempt to compete for your business, but merely a means for you to have commitments which achieve the Minimum Level of Participation, you should report this information to the Authority. Examples of this circumstance include situations where the MBE/WBE is acting in the manner of a broker in a trade where this is not the common practice. A quote which simply adds a margin to a price from a non-MBE/WBE is not competitive and need not be accepted. To do so simply to achieve the Minimum Level of Participation is contrary to the goals of the MBE/WBE Program.
8. Final decisions regarding responsive bids and compliance with requirements will be solely at the discretion of the Redevelopment Authority.

C. RESPONSIBILITY

- (1) The submittals of each bidder are subject to review to determine whether the bidder has discriminated in the selection of manufacturers, subcontractors and suppliers. If a bidder has met the MPLs for MBE/WBE participation, the bidder will be presumed not to have discriminated in their selections. Where the MPLs are not met, the Local Public Agency will determine whether discrimination has occurred. If, after investigation including a review of Form DCED-CCD-286, it is found that discrimination has occurred, the reviewed bidder shall thereby be deemed to be not responsible and the bid will be rejected.
- (2) Commitments to MBE and WBE firms made at the time of bidding must be maintained throughout the term of the contract, unless a change in commitment to these firms is preapproved by the Local Public Agency or the administering agency performing the evaluation of the Bid.

D. ACCESS TO INFORMATION

That Local Public Agency may obtain documents and information from any Bidder, contractor, subcontractor, supplier, or manufacturer that may be required in order to ascertain Bidder or contractor responsibility. Failure to provide requested information may result in the contractor being declared not responsible.

SPECIAL NOTICE REGARDING MINORITY AND WOMEN'S BUSINESS ENTERPRISES:

The Local Public Agency will provide a list of MBE/WBE firms within the trade area to be contacted to provide subcontracted services, materials and supplies which may be needed for this project. The bidder may contact these firms, and any other certified MBE/WBE firms known to the bidder, to achieve the minimum participation level (MPL).

Contacts and commitments must be recorded on Form DCED-CCD-286 (contained in the bidding documents) in accordance with the instructions on the form. The completed Form DCED-CCD-286 **must** be submitted with the bid, or the bid will be rejected as nonresponsive.

If the Form DCED-CCD-286 submitted with the bid show commitments resulting from contacts with certified MBE/WBE firms achieving at least the minimum participation level of 5% for MBE firms and 3% for WBE firms, the bid will be considered responsive, and in this regard, the bidder will be presumed to be responsible. If the MPLs are not achieved by such contact/commitments, the bidder must report why the MPLs were not achieved. Information regarding this report is contained instructions that follow.

If this is the first bid submitted to the Local Public Agency under this MBE/WBE plan, the bidder is urged to contact the Agency at least 2 days prior to the bid opening to review preparation of the Form DCED-CCD-286. Phone Daniel Lyons at 717-274-1401x133.

THIS PAGE INTENTIONALLY LEFT BLANK

Contractor's Name: _____

Address: _____

Telephone No.: _____

Fax No.: _____

Federal I.D. No.: _____

E-Mail: _____

SAM.GOV UEI #: _____

**PROPOSAL
REDEVELOPMENT AUTHORITY OF
THE COUNTY OF LEBANON
CONTRACT C-5-22-JB
MAY, 2022**

Redevelopment Authority of the
County of Lebanon
137 W. Penn Avenue
Cleona, PA 17042

Gentlemen:

Pursuant to and in compliance with your request inviting Proposals for the general construction of the above project and having carefully examined the contract documents, comprising the drawings, specifications and all other documents bound therewith; together with all addenda or bulletins thereto; and being familiar with the site and various conditions affecting the work; the undersigned hereby offers to furnish all plans, labor, supervision, materials, supplies, equipment and other facilities and things necessary or incidental to the work as required by and in strict accordance with the applicable provisions of the plans and specifications, contract documents, and of all addenda or bulletins issued by the Owner for the following prices:

Lump sum price: \$ _____

\$ _____ 00/100

In submitting this Bid, the Bidder understands that the right is reserved by the Redevelopment Authority of the County of Lebanon to reject any and all Bids. If written notice of the acceptance of this Bid is mailed, telegraphed or delivered to the undersigned within thirty (30) days after the opening thereof, or at any time thereafter before this Bid is withdrawn, the undersigned agrees to execute and deliver an agreement in the prescribed form and furnish the required bonds within ten (10) days after the agreement is presented to him for signature.

1. Security in the sum of _____ Dollars (\$ _____) in the form of _____ is submitted herewith in accordance with the INSTRUCTIONS TO BIDDERS.
2. Attached hereto is an affidavit in proof that the undersigned has not entered into a collusive agreement with any person in respect to this Bid or the submitting of Bids for the contract for which this Bid is submitted.
3. The Bidder certifies that he does not maintain or provide for his employees any segregated facilities at any of his establishments, and that he does not permit his employees to perform their services at any location, under his control, where segregated facilities are maintained. The Bidder certifies further that he will not maintain or provide for his employees any segregated facilities at any of his establishments, and that he will not permit his employees to perform their services at any location under his control where segregated facilities are maintained. The Bidder agrees that a breach of this certification will be a violation of the Equal Opportunity clause in any contract resulting from acceptance of this Bid. As used in this certification, the term "segregated facilities" means any waiting rooms, work areas, rest rooms and washrooms, restaurants and other eating areas, time clocks, locker rooms and other storage or dressing areas, parking lots, drinking fountains, recreation or entertainment areas, transportation, and housing facilities provided for employees which are segregated by explicit directive or are in fact segregated on the basis of race, color, religion, or national origin, because of habit, local custom, or otherwise. The Bidder agrees that (except where he has obtained identical certification from proposed subcontractors for specific time periods) he will obtain identical certification from proposed subcontractors prior to the award of subcontractors exceeding \$10,000 which are not exempt from the provisions of the Equal Opportunity clause, and that he will retain such certifications in his files.
4. The Bidder also agrees to conform to the Pennsylvania Non-Discrimination Clause contained in these bidding documents.

Date: _____

Bidder

Official Address:

By: _____

Title: _____

BID BOND

KNOW ALL MEN BY THESE PRESENTS, that we the undersigned,

as PRINCIPAL, and _____
as SURETY, are held and firmly bound unto Redevelopment Authority of the County of Lebanon, hereinafter called the "Local Public Agency", in the penal sum of _____ Dollars (\$ _____) lawful money of the United States, for the payment of which sum well and truly to be made, we bind ourselves, our heirs, executors, administrators, successors, and assigns, jointly and severally, firmly by these presents.

THE CONDITION OF THIS OBLIGATION IS SUCH, that whereas the Principal has submitted the accompanying Bid, dated _____, 20 ____, for

NOW, THEREFORE, if the Principal shall not withdraw said Bid within the period specified therein after the opening of the same, or, if no period be specified, within thirty (30) days after the said opening, and shall within the period specified therefore, or if no period be specified, within ten (10) days after the prescribed forms are presented to him for signature, enter into a written Contract with the Local Public Agency in accordance with the Bid as accepted, and give bond with good and sufficient surety or sureties, as may be required, for the faithful performance and proper fulfillment of such Contract; or in the event of the withdrawal of said Bid within the period specified, or the failure to enter into such Contract and give such bond within the time specified, if the Principal shall pay the Local Public Agency the difference between the amount specified in said Bid and the amount for which the Local Public Agency may procure the required work or supplies or both, if the latter be in excess of the former, then the above obligation shall be void and of no effect, otherwise to remain in full force and virtue.

IN WITNESS WHEREOF, the above-bounded parties have executed this instrument under their several seals this ____ day of _____, 20__, the name and corporate seal of each corporate party being hereto affixed and these presents signed by its undersigned representative, pursuant to authority of its governing body.

INDIVIDUAL OR PARTNERSHIP PRINCIPALS

_____(SEAL)
_____(SEAL)
In the presence of: _____(SEAL)
_____(SEAL)

CORPORATE PRINCIPAL

ATTEST: _____
By: _____(SEAL)

SURETY

ATTEST: _____
By: _____(SEAL)

Countersigned:

By: _____
Attorney-in-Fact
State of _____

CERTIFICATE AS TO CORPORATE PRINCIPAL

I, _____, certify that I am the _____
_____, Secretary of the Corporation named as Principal in the within bond; that _____
_____, who signed the said bond on behalf of the Principal was then _____ of
said Corporation; that I know his signature, and his signature thereto is genuine; and that said bond was duly
signed, sealed and attested to for and in behalf of said Corporation by authority of this governing body.

Title: _____

(CORPORATE SEAL)

STATEMENT OF BIDDER'S QUALIFICATIONS

All questions must be answered and the data given must be clear and comprehensive. This statement must be notarized. If necessary, questions may be answered on separate attached sheets. The Bidder may submit any additional information he desires.

1. Name of Bidder.
2. Permanent main office address.
3. When organized.
4. If a corporation, where incorporated.
5. How many years have you been engaged in the contracting business under your present firm or trade name?
6. Contracts on hand: (Schedule these, showing amount of each contract and the appropriate anticipated dates of completion.)

7. General character or work performed by your company.

8. Have you ever failed to complete any work awarded to you?
If so, where and why? (Submit attachment.)

9. Have you ever defaulted on a contract?
If so, where and why? (Submit attachment.)

10. List the more important projects recently completed by your company, stating the approximate cost for each, and the month and year completed. (Submit attachment.)

11. List your major equipment available for this contract.

12. Experience in construction work similar in importance to this project.

13. Background and experience of the principal members of your organization, including the officers.

14. Credit available: \$ _____.

15. Give bank reference: _____

16. Will you, upon request, fill out a detailed financial statement and furnish any other information that may be required by the Redevelopment Authority of the County of Lebanon in verification of the recitals comprising this Statement of Bidder's Qualification?

Dated at _____ this _____ day of _____, 20____.

(Name of Bidder)

By _____

Title _____

State of _____)

County of _____)

_____ being duly sworn deposes and says that he is
_____ of _____

and that the answers to the foregoing questions and all statements therein contained are true and correct.

Subscribed and sworn to before me this _____ day of _____, 20____.

Notary Public

My commission expires _____, 20____

MBE/WBE SECTION 3 CONTRACT SOLICITATION AND COMMITMENT STATEMENT

(1) Name of Bidder	(2) IFB Number C-1-20-SLT-ARRP-2
Address	Bid Opening Date
Telephone Number	Contact Person

(8) NOTE: List those certified minority/women owned businesses from which you solicited quotes or which contacted you and gave you quotes in regard to this invitation for bid. Bidder's contract with Subcontractors and suppliers should be at least five days prior to the bid opening date.

*(3) COMPANY NAME EIN/SSN TELEPHONE NUMBER	(4) MBE (X)	(4) WBE (X)	(4) Sec. 3 (X)	(5) TYPE OF CONSTRUCTION, EQUIPMENT, SERVICES AND/OR SUPPLIES TO BE PROVIDED TO THE PROJECT	(6) TOTAL DOLLAR AMOUNT OF QUOTE RECEIVED	*(7) TOTAL COMMITMENT DOLLAR AMOUNT

(9) NOTE Minimum Levels (MPL): MBE-5%, WBE-3%
 A presumption of responsibility may be made if the dollar commitment of MBE/WBE reflects this minimum participation level.

(10) Prepared By:	Telephone Number/E-mail Address:
-------------------	----------------------------------

Use additional sheets if necessary.

**INSTRUCTIONS FOR COMPLETION OF
THE MBE/WBE SUBCONTRACTOR AND
SUPPLIER SOLICITATION AND COMMITMENT FORM (DCED-CCD-286)**

The purpose of this form is to determine whether the bidder has discriminated in the selection of subcontractors and suppliers.

INSTRUCTIONS FOR BLOCKS 1 AND 2

1. Provide your company name, address, telephone number, fax number, e-mail address and contact person.
2. Provide the contract number, bid opening date, and total amount of the bid. If more than one base bid is submitted, provide the total bid amount for Base Bid #1.

INSTRUCTIONS FOR BLOCKS 3 - 7

3. Enter the official subcontractor or supplier's company name exactly as it appears on the Department of General Services (DGS) list of certified MBEs/WBEs at the DGS website (<http://www.dgs.state.pa.us/>) or Department of Transportation (PennDOT) website (www.dot.state.pa.us). Do not use D/B/A (Doing Business As) name. List the address, zip code, telephone number with area code, and contact person's name.
4. Indicate whether the firm is a DGS certified MBE or WBE. Place a (x) in the appropriate column. If the firm is both a DGS certified MBE and a DGS certified WBE, the bidder will receive credit for the firm as either an MBE or a WBE.
5. Briefly describe the specific type of work to be performed and/or materials to be supplied by the listed DGS certified MBE or WBE. In order to count towards reaching the MPLs, bidders must solicit DGS certified MBEs/WBEs in the areas in which they are certified. For example, if an MBE/WBE is certified for electrical supplies and the bidder lists plumbing supplies, the bidder will not receive credit. Geographical location may not be used as a reason for limiting solicitation.
6. Enter the total dollar (\$) amount of the quote received. If the quote was received in the form of unit prices or hourly rates, a total dollar amount must still be provided. If the subcontractor did not respond to the bidder, the bidder must indicate "No Response." Copies of all MBE/WBE quotes must be submitted with the bid.
7. Enter the total dollar (\$) amount of the contractual commitment made to the listed MBE/WBE. If the bidder does not use the total quote from a MBE/WBE because a lower priced quote was received, the bidder must submit a copy of the lower priced quote with its bid. On partial commitments, the bidder must explain why only a partial commitment was made and must submit a copy of the lower priced quote.

INSTRUCTIONS FOR SUBMISSION OF FORM DCED-CCD-286 AND OTHER DOCUMENTATION

8. The bidder must complete and submit Form DCED-CCD-286 with its bid.
9. The bidder must include with the Form DCED-CCD-286 all solicited and unsolicited quotes received by the bidder from MBEs and WBEs as long as the quotes are within the scope of work.

FURTHER INSTRUCTIONS

10. The bidder's contact with MBE/WBE subcontractors and suppliers should be a minimum of (10) days prior to bid opening date. This will ensure that MBE/WBEs have sufficient time to prepare a quote. Ten days is a guide. However, adequate time must be provided to all subcontractors and suppliers to respond.

If the minimum participation levels (MPLs) for this project are not achieved, you must provide a written explanation explaining the failure to achieve the MPLs for MBEs and/or WBEs. Failure to do so will result in rejection of the bid.

If there are any questions/comments concerning this form, please contact the issuing agency contracting officer. If additional forms are needed, you are permitted to photocopy form.

AGREEMENT FOR SITE PREPARATION

THIS AGREEMENT, made this _____ day of _____, 20____, by and between _____ (a corporation organized and existing under the laws of the State of _____); (a partnership consisting of _____); (an individual trading as _____), hereinafter called the "Contractor," and the REDEVELOPMENT AUTHORITY OF THE COUNTY OF LEBANON, PENNSYLVANIA, hereinafter called the "Local Public Agency."

WITNESSETH, that the Contractor and the Local Public Agency for the considerations stated herein mutually agree as follows:

ARTICLE 1. STATEMENT OF WORK. The Contractor shall furnish all supervision, technical personnel, labor, materials, machinery, tools, equipment and services, including utility and transportation services, and perform and complete all work required for the construction of the Improvements embraced in the Site Preparation, namely:

Contract C-5-22-JB, Jonestown Borough, Lebanon County, Pennsylvania, East Blackberry Street Reconstruction.

and required supplemental work for the _____ contract _____, all in strict accordance with the Contract Documents for Site Preparation, including all Addenda thereto, numbered _____, dated _____, all as prepared by _____, acting and in these Contract Documents for Site Preparation, referred to as the "Engineer."

ARTICLE 2. THE CONTRACT PRICE. The Local Public Agency will pay the Contractor for the performance of the Contract in current funds, for the total quantities of work performed at the unit prices stipulated in the Bid for the several respective items of work completed subject to additions and deductions as provided in Section 109 hereof.

ARTICLE 3. CONTRACT. The executed contract documents shall consist of the following:

- a. This Agreement
- b. Addenda (if any)
- c. Invitation for Bids
- d. Instructions to Bidders
- e. Signed copy of Bid and Resolution Awarding Contract
- f. General Conditions (Part I, Part II and Part III)
- g. Special Conditions (Part IV)
- h. Technical Specifications
- i. Drawings (as listed in the Schedule of Drawings)

This Agreement, together with other documents enumerated in this ARTICLE 3, which said other documents are as fully a part of the contract as if hereto attached or herein repeated, forms the contract between the parties hereto. In the event that any provision in any component part of this contract conflicts with any provision of any other component part, the provision of the component part first enumerated in this ARTICLE 3 shall govern, except as otherwise specifically stated.

ARTICLE 4. STIPULATION AGAINST LIENS. The Contractor agrees to execute and record a Stipulation Against Liens in the form provided herewith prior to commencement of any work required thereby, or the acquisition of any materials therefor.

IN WITNESS WHEREOF, the parties hereto have caused this AGREEMENT to be executed in three original copies on the day and year first above written.

Attest:

(Contractor)

By: _____

Title: _____

Address: _____

Attest:

REDEVELOPMENT AUTHORITY OF THE
COUNTY OF LEBANON, PENNSYLVANIA

Secretary/Assistant Secretary

By _____
Chairman/Vice Chairman

CORPORATE CERTIFICATION

I, _____, certify that I am the _____ of the Corporation named as Contractor herein; that _____ who signed this Agreement on behalf of the Contractor, was the _____ of said Corporation; that said Agreement was duly signed for and in behalf of said Corporation by authority of its governing body, and is within the scope of its corporate powers.

Signed _____

Title _____

(Corporate Seal)

STIPULATION AGAINST LIENS

REDEVELOPMENT AUTHORITY OF THE)	IN THE COURT OF COMMON PLEAS OF
COUNTY OF LEBANON, PENNSYLVANIA,)	LEBANON COUNTY, PENNSYLVANIA
<i>Owner</i>)	
)	
VS.)	
)	
)	
)	
<i>Contractor</i>)	MECHANICS LIEN DOCKET NO. _____

WHEREAS, the Redevelopment Authority of the County of Lebanon, Pennsylvania, a body politic and corporate, in the City of Lebanon, Commonwealth of Pennsylvania, is about to execute contemporaneously herewith a contract with

for _____

NOW, THEREFORE, _____, 20____, at the time of and immediately before the execution of the contract and before any authority has been given by the said Redevelopment Authority of the County of Lebanon, Pennsylvania, to the said Contractor to commence work on the said project or purchase materials for the same, in consideration of the making of the said contract with the said Contractor and for the further consideration of One (\$1.00) Dollar paid to the said Contractor by the said Redevelopment Authority of the County of Lebanon, Pennsylvania, it is agreed that no mechanic's claims or other liens shall be filed against the building and/or lot of ground appurtenant thereto by the said Contractor nor any subcontractor, nor by any of the material men or workmen or any person for any materials or labor or extra materials or labor purchased or furnished in connection with the construction of the said project or any part thereof, the right to file such claims or liens being expressly waived and relinquished herewith.

(SEAL)	REDEVELOPMENT AUTHORITY OF THE
ATTEST:	COUNTY OF LEBANON, PENNSYLVANIA
_____	By _____
	Executive Director

(SEAL)	_____
ATTEST:	(Contractor)
_____	By _____
	Title _____

**INSTRUCTIONS FOR PREPARATION OF PERFORMANCE BOND, LABOR AND
MATERIALMEN'S BONDS, AND, IF REQUIRED,
HIGHWAY OCCUPANCY PERFORMANCE BOND**

1. Individual sureties, partnerships, or corporations not in the surety business will not be acceptable.
2. The name of the Principal shall be shown exactly as it appears in the Contract.
3. The penal sum shall be not less than that required by the Specifications.
4. If the Principals are partners, or joint venturers, each member shall execute the bond as an individual, with his place of residence shown.
5. If the Principal is a corporation, the bond shall be executed under its corporate seal, the fact shall be stated, in which case a scroll or adhesive seal shall be affixed following the corporate name.
6. The official character and authority of the person(s) executing the bond for the Principal, if a corporation, shall be certified by the secretary thereof under the corporate seal, OR there may be attached copies of so much of the records of the corporation as will evidence the official character and authority of the officer signing, duly certified by the secretary or assistant secretary, under the corporate seal, to be true copies.
7. The current Power of Attorney of the person signing for the surety company must be attached to the bond.
8. The date of the bond must NOT be prior to the date of the Contract.
9. The following information must be placed on the bond by the surety company:
 - a. The rate of premium in dollars per thousand; and
 - b. The total dollar amount premium charged.
10. The signature of a witness shall appear in the appropriate place, attesting to the signature of each party to the bond.
11. Type or print the name underneath EACH SIGNATURE appearing on the bond.
12. An executive copy of the bond must be attached to each copy of the Contract (original counterpart) intended for signing.

**INSTRUCTIONS FOR PREPARATION OF HIGHWAY OCCUPANCY
PERFORMANCE BOND, IF REQUIRED**

The foregoing requirements shall also apply to preparation of the Highway Occupancy Performance Bond, where such bond is required, except as described here:

1. The Principal shall be identified as the Contractor and the Permittee collectively. The Permittee will be identified by the Local Public Agency.
2. The full and just sum shall be an amount determined by the Pennsylvania Department of Transportation as described in Paragraph 15. B.1. of the Instructions to Bidders (page 6 of these documents).

In lieu of a Highway Occupancy Performance Bond, the Pennsylvania Department of Transportation will accept an Irrevocable Letter of Credit. This letter must meet their requirements for said letter.

PERFORMANCE BOND

KNOW ALL MEN BY THESE PRESENTS, that we _____

as Principal, hereinafter called Contractor, and _____

as Surety, hereinafter called Surety, are held and firmly bound unto Redevelopment Authority of the
County of Lebanon as Oblige, hereinafter called Owner, in the bid amount of

(\$_____) Dollars, lawful money of the United States, for the payment of which sum well
and truly to be made, we, the Contractor and Surety, bind ourselves, our heirs, administrators, executors,
successors and assigns, jointly and severally, firmly by these presents.

WHEREAS, said Contractor has by written agreement dated _____, 20 __, entered
into a certain Contract with said Owner for furnishing and delivering all materials, equipment and
machinery, also the furnishing of all labor and complete construction in accordance with the plans and
specifications under Contract for _____

which Contract and all of the Contract Documents therein referred to for said work shall be deemed a part
thereof as fully as if set out herein.

NOW, THEREFORE, THE CONDITION OF THIS OBLIGATION IS SUCH that, if the
Contractor shall promptly and faithfully perform the Contract, or any amendments or extension of, or
additions to said Contract on his part within the time and in the manner therein provided and satisfy all
claims and demands incurred in or for the same, or growing out of the same, or for injury, or damage to
persons or property in the performance thereof, and shall fully indemnify and save harmless the said
Owner from any and all cost and damage which the said Owner may suffer by reasons of failure so to do,
and shall fully reimburse and repay the said Owner any and all outlay and expense which it may incur by
reason of such default, then this obligation shall be null and void; otherwise it shall remain in full force
and virtue.

ALSO, that if the above Principal shall remedy without cost to the Owner any defects which may
develop during a period of one (1) year from the date of the issuance of the final certificate of completion
of the work performed under said Contract then this part of the obligation shall be null and void;
otherwise it shall remain in full force and effect.

Whenever Contractor shall be, and declared by Owner to be in default under the Contract, the
Owner having performed Owner's obligations thereunder, the Surety may promptly remedy the default,
or shall promptly:

1. Complete the Contract in accordance with its terms and conditions; or
2. Obtain a bid or bids for submission to Owner for completing the Contract in accordance with
its terms and conditions, and upon determination by Owner and Surety of the lowest
responsible bidder arrange for a Contract between such bidder and Owner and make
available as work progresses (even though there should be a default or a succession of
defaults under the Contract or Contracts of completion arranged under this paragraph)
sufficient funds to pay the cost of completion less the balance of the Contract price; but not
exceeding, including other costs and damages for which the Surety may be liable hereunder,
the amount set forth in the first paragraph hereof. The term "balance of the Contract price"
as used in the paragraph, means the total amount payable by Owner to Contractor under the

Contract and any amendments thereto, less the amount properly paid by Owner to Contractor.

The said Surety, for value received, hereby stipulates and agrees that no change, extension of time, alteration or addition to the terms of the Contract or to the work to be performed thereunder of the specifications accompanying the same shall in any wise affect its obligations on this bond, and it does hereby waive notice of any such change, extension of time, alteration or addition to the terms of the Contract or to the work of the specifications.

Signed, sealed and delivered in three (3) counterparts this _____ day of _____, 20__.

INDIVIDUAL OR PARTNERSHIP PRINCIPALS

_____(SEAL)

_____(SEAL)

in the presence of:

_____(SEAL)

_____(SEAL)

CORPORATE PRINCIPAL

ATTEST:

By: _____(SEAL)

Title

SURETY

ATTEST:

By: _____(SEAL)

Countersigned:

By: _____

Attorney-in-Fact, State of _____

CERTIFICATE AS TO CORPORATE PRINCIPAL

I, _____, certify that I am the _____ of the Corporation named as Principal in the within bond; that _____, who signed the said bond on behalf of the Principal was then _____ of said corporation; that I know his signature, and his signature thereto is genuine; and that said bond was duly signed, sealed, and attested to for and in behalf of said corporation by authority of this governing body.

(Corporate Seal)

Title: _____

LABOR AND MATERIALMEN'S BOND

KNOW ALL MEN BY THESE PRESENTS, That we, _____
_____,
hereinafter called "Principal" and _____,
_____, hereinafter called "Surety", are held and firmly bound
unto Redevelopment Authority of the County of Lebanon, hereinafter called "Owner", in the bid amount of
_____ (\$_____) Dollars, in lawful money of the United States, for the payment of
which sum well and truly to be made, we bind ourselves, our heirs, executors, administrators and successors,
jointly and severally, firmly by these presents.

THE CONDITION OF THIS OBLIGATION is such that Whereas, the Principal entered into a
certain Contract with the Owner, dated the _____ day of _____, 20____, a copy of which
is hereto attached and made a part hereof for _____
_____.

NOW, THEREFORE, if the Principal shall promptly make payment to all persons, firms,
subcontractors, and corporations furnishing materials for or performing labor in the prosecution of the work
provided for in such Contract, and any authorized extension or modification thereof, including all amounts
due for materials, lubricants, oil, gasoline, coal and coke, repairs on machinery, equipment and tools,
consumed or used in connection with the construction of such work, and all insurance premiums on said
work, and for all labor, performed in such work whether by subContractor or otherwise, then this obligation
shall be void; otherwise to remain in full force and effect.

PROVIDED, FURTHER, that the said surety, for value received, hereby stipulates and agrees that
no change, extension of time, alteration or addition to the terms of the Contract or to the work to be
performed thereunder or the specifications accompanying the same shall in any wise affect its obligation on
this bond, and it does hereby waive notice of any such change, extension of time, alteration or addition to
the terms of the Contract or to the work or to the specifications.

PROVIDED, FURTHER, that no final settlement between the Owner and the Contractor shall
abridge the right of any beneficiary hereunder, whose claim may be unsatisfied.

Signed, sealed and delivered in three (3) counterparts this _____ day of _____, 20 ____.

INDIVIDUAL OR PARTNERSHIP PRINCIPALS

_____(SEAL)

_____(SEAL)

in the presence of:

_____(SEAL)

_____(SEAL)

CORPORATE PRINCIPAL

ATTEST:

By: _____(SEAL)

Title

SURETY

ATTEST:

Countersigned: _____

By: _____(SEAL)

By: _____

Attorney-in-Fact, State of _____

CERTIFICATE AS TO CORPORATE PRINCIPAL

I, _____, certify that I am the _____ of the Corporation named as Principal in the within bond; that _____ who signed the said bond on behalf of the Principal was then _____ of said corporation; that I know his signature, and his signature thereto is genuine; and that said bond was duly signed, sealed, and attested to for and in behalf of said corporation by authority of this governing body.

(Corporate Seal)

Title: _____

HIGHWAY OCCUPANCY PERFORMANCE BOND

KNOW ALL MEN BY THESE PRESENTS, that we,

_____, of _____,
_____, and _____,
_____, of _____,

_____ as PRINCIPAL, collectively identified as PRINCIPAL, for the purpose of this Bond only, and _____

_____, as SURETY, are held and firmly bound unto the Commonwealth of Pennsylvania, as OBLIGEE, in the full and just sum of _____

(\$ _____) Dollars, lawful money of the United States of America, to be paid to the said Commonwealth of Pennsylvania, or its assigns, to which payment well and truly to be made, we bind ourselves, our heirs, executors, administrators, successors and assigns, jointly and severally, firmly by these presents.

WHEREAS, the above bounden PRINCIPAL has applied for or is about to apply for a permit from the Commonwealth of Pennsylvania, Department of Transportation, under the provisions of 67 Pa. Code Chapter 459 to perform work on the PRINCIPAL'S facilities located over, under and/or on Legislative Route (Application) _____, between stations _____ and _____, in _____, _____ County; and

WHEREAS, the PRINCIPAL is required to furnish a Bond pursuant to 67 Pa. Code Chapter 459.5(b), because a substantial amount of work will be performed under the permit.

NOW, THEREFORE, the condition of this obligation is such that, if the above bounden PRINCIPAL shall in all respects comply with and faithfully perform the terms and conditions of the Permit and all applicable provisions of 67 Pa. Code Chapter 459, and shall save and keep harmless the OBLIGEE from any damages or losses from any cause growing out of work performed on the portion of State Highway, then this obligation is to be void; but otherwise is to be and remain in full force and effect.

IT IS further provided that any alterations which may be made in the terms of the Permit or in the payment of costs due under it, or the giving by the OBLIGEE of any extension of time for the performance of the work or any other forbearance on the part of either the OBLIGEE or the PRINCIPAL to the other, shall not in any way release the PRINCIPAL and the SURETY or SURETIES or either or any of them, their heirs, executors, administrators, successors and assigns, from their liability hereunder, notice to the SURETY or SURETIES of any such alteration, extension or forbearance being hereby waived.

IT IS further provided that the duration of the obligation under this Bond shall be for the period during which work is performed and for one year after the satisfactory completion of all permitted work.

PROVIDED, FURTHER, that in case of default of the PRINCIPAL, in any respect, action on this Bond may be begun forthwith, and the PRINCIPAL and SURETY, jointly and severally do hereby authorize and empower any attorney of any Court of record in Pennsylvania or elsewhere, to appear for and to enter judgment against them, jointly and severally, for the aforementioned sum, with or without defalcation, with costs of suit, release of errors, without stay of execution and with 10% attorney's fees added for collection; and waiving inquisition on any real estate and exemption of any property whatsoever, authorizing condemnation of same and immediate issuance of a Writ of Execution, and releasing and waiving relief from any and all appraisal, stay of execution, or exemption laws of any state, now in force or hereinafter to be passed.

Time limitations set forth in this Bond shall not be deemed to relieve the PRINCIPAL of liability for items exceeding the time limitations set forth in 67 Pa. Code Chapter 459.

IN WITNESS WHEREOF, the PRINCIPAL and SURETY have executed this Bond under seal this _____ day of _____, 20____.

_____(SEAL)
PRINCIPAL (Permit Applicant)

ATTEST:

By _____(SEAL)

By _____(SEAL)

SURETY COMPANY

ATTEST:

By _____
Title

APPROVED AS TO FORM AND LEGALITY

By _____
Chief Counsel

By _____
Deputy Attorney General

Dated: _____

GOOD FAITH EFFORT

The following minority business referral agencies will be contacted: SBA, State OMBE, and others: (List)

This is to certify that _____
will abide by and initiate in all our contracts, to the greatest extent feasible, the requirements of Executive Order 11625.

Signature

Title Date

GENERAL SPECIFICATIONS

GENERAL CONDITIONS PART I

101. DEFINITIONS

Whenever used in any of the Contract Documents, the following meanings shall be given to the terms herein defined:

a. The term "Contract" means the Contract executed by the Local Public Agency and the Contractor, of which these GENERAL CONDITIONS, PARTS I, II, and III form a part.

b. The term "Local Public Agency" means the Redevelopment Authority of the County of Lebanon which is authorized to undertake this Contract.

c. The term "Contractor" means the person, firm or corporation entering into the Contract with the Local Public Agency to construct and install the improvements embraced in this Site Preparation Contract.

d. The term "Project Area" means the site within which are the specified Contract limits of the improvements contemplated to be constructed in whole or in part under this Contract.

e. The term "Engineer" means Engineer in charge, serving the Local Public Agency with architectural or engineering services, his successor, or any person or persons employed by said Local Agency for the purpose of directing or having in charge the work of Site Preparation embraced on this Contract, the said Engineer acting directly or indirectly through any Assistant Engineer having general charge of the work or through any assistant having immediate charge of a portion thereof limited by the particular duties entrusted to him.

f. The term "Local Government" means the municipality in which the Project Area is situated.

g. The term "Contract Documents" means and shall include the following: Executed Agreement; Addenda (if any); Invitation for Bids; Instructions to Bidders; Signed Copy of Bid; General Conditions, Parts I, II, and III; Special Conditions; Technical Specifications; and Drawings (as listed in the Schedule of Drawings).

h. The term "Drawings" means the drawings listed in the Schedule of Drawings.

i. The term "Technical Specifications" means that part of the Contract Documents which describes outlines and stipulates: the quality of the materials to be furnished; the quality of workmanship required and the methods to be used in carrying out the construction work to be performed under this Contract.

j. The term "Addendum" or "Addenda" means any changes, revisions or clarifications of the Contract Documents which have been duly issued by the Local Public Agency to prospective Bidders prior to the time of receiving Bids.

102. SUPERINTENDENCE BY CONTRACTOR

a. Except where the Contractor is an individual and gives his personal superintendence to the work, the Contractor shall provide a competent superintendent, satisfactory to the Local Public Agency and the

Engineer, or the work at all times during working hours with full authority to act for him. The Contractor shall also provide an adequate staff for the proper coordination and expediting of his work.

b. The Contractor shall lay out his own work and he shall be responsible for all work executed by him under the Contract. He shall verify all figures and elevations before proceeding with the work and will be held responsible for any error resulting from his failure to do so.

103. SUBCONTRACTS

- a. The Contractor shall not execute an agreement with any subcontractor or permit any subcontractor to perform any work included in this Contract until he has submitted a noncollusive affidavit from the subcontractor in substantially the form shown below and has received written approval of such subcontractor from the Local Public Agency.
- b. No proposed subcontractor shall be disapproved by the Local Public Agency except for cause.
- c. The Contractor shall be as fully responsible to the Local Public Agency for the acts and omissions of his subcontractors, and of persons either directly or indirectly employed by them, as he is for the acts and omissions of persons directly employed by him.
- d. The Contractor shall cause appropriate provision to be inserted in all subcontracts relative to the work to require compliance by each subcontractor with the applicable provisions of the Contract for the Improvements embraced in the State Preparation.
- e. Nothing contained in the Contract shall create any contractual relation between any subcontractor and the Local Public Agency.

104. OTHER CONTRACTS

The Local Public Agency may award, or may have awarded other Contracts for additional work, and the Contractor shall cooperate fully with such other Contractors, by scheduling his own work with that to be performed under other Contracts as may be directed by the Local Public Agency. The Contractor shall not commit or permit any act which will interfere with the performance of work by any other Contractor as scheduled.

105. FITTING AND COORDINATION OF THE WORK

The Contractor shall be responsible for the proper fitting of all work and for the coordination of the operations of all trades, subcontractors, or material men engaged upon this Contract. He shall be prepared to guarantee to each of his subcontractors the locations and measurements which they may require for the fitting of their work to all surrounding work.

106. MUTUAL RESPONSIBILITY OF CONTRACTORS

If, through acts or neglect on the part of the Contractor, any other Contractor or any subcontractor shall suffer loss or damage on the work, the Contractor shall settle with such other Contractor or subcontractor by agreement or arbitration, if such other Contractor or subcontractor will so settle. If such other Contractor or subcontractor shall assert any claim against the Local Public Agency on account of any damage alleged to have been so sustained, the Local Public Agency will notify this Contractor, who shall defend at his own expense any suit based upon such claim, and, if any judgment or claims against the Local Public Agency shall be allowed, the Contractor shall pay or satisfy such judgment or claim and pay all costs and expenses in connection therewith.

107. PROGRESS SCHEDULE

a. The Contractor shall submit for approval immediately after execution of the Agreement, a carefully prepared Progress Schedule, showing the proposed dates of starting and completing each of the various sections of the work, the anticipated monthly payments to become due the Contractor, and the accumulated percent of progress each month.

108. PAYMENTS TO CONTRACTOR

1. Partial Payments

a. The Contractor shall prepare his requisition for partial payment as of the last day of the month and submit it, with the required number of copies, to the Engineer for his approval. The amount of the payment due the Contractor shall be determined by adding to the total value of work completed to date, the value of materials properly stored on the site and deducting 10% of the amount due the Contractor until 50% of the Contract is complete and 5% of the amount due the Contractor on the remaining work. When the Contract is substantially completed, the Contractor shall be paid in full, less one and one-half times the amount as is required to complete any then remaining, uncompleted minor items, which amount shall be certified by the Engineer. The total value of work completed to date shall be based on the estimated quantities of work completed and on the unit prices contained in the Agreement. The value of materials properly stored on the site shall be based upon the estimated quantities of such materials and the invoice prices. Copies of all invoices shall be available for inspection of the Engineer.

- b. Monthly or partial payments made by the Local Public Agency to the Contractor are moneys advanced for the purpose of assisting the Contractor to expedite the work of construction. All material and completed work covered by such monthly or partial payments shall remain the property of the Contractor and he shall be responsible for the care and protection of all materials and work upon which payments have been made. Such payments shall not constitute a waiver of the rights of the Local Public Agency to require the fulfillment of all terms of the Contract and the delivery of all improvements embraced in this Contract complete and satisfactory to the Local Public Agency in all details.

2. Final Payment

- a. After final inspection and acceptance by the Local Public Agency of all work under the Contract, the Contractor shall prepare his requisition for final payment which shall be based upon the carefully measured or computed quantity of each item of work at the applicable unit prices stipulated in the Agreement. The total amount of the final payment due the Contractor under this Contract shall be the amount computed as described above less all previous payments. Final payment to the Contractor shall be made subject to his furnishing the Local Public Agency with a release in satisfactory form of all claims against the Local Public Agency arising under and by virtue of his Contract, other than such claims, if any, as may be specifically excepted by the Contractor from the operation of the release as provided under the section entitled DISPUTES under GENERAL CONDITIONS, PART I.
- b. The Local Public Agency, before paying the final estimate, may require the Contractor to furnish releases or receipts from all subcontractors having performed any work and all persons having supplied materials, equipment (installed on the Project) and services to the Contractor, if the Local Public Agency deems the same necessary in order to protect its interest. The Local Public Agency, however, may, if it deems such action advisable, make payment in part or in full to the Contractor without requiring the furnishing of such releases or receipts and any payments so made shall in no wise impair the obligations of any surety or sureties furnished under this Contract.
- c. Withholding of any amount due the Local Public Agency under the section entitled "Liquidated Damages" under SPECIAL CONDITIONS, shall be deducted from the final payment due the Contractor.

3. Withholding Payments

The Local Public Agency may withhold from any payment otherwise due the Contractor so much as may be necessary to protect the Local Public Agency and, if so elects, may also withhold any amounts due from the Contractor to any subcontractors or material dealers, for work performed or material furnished by them. The foregoing provisions shall be construed solely for the benefit of the Local Public Agency and will not require the Local Public Agency to determine or adjust any claims or disputes between the Contractor and his subcontractors or material dealers, or to withhold any moneys for their protection unless the Local Public Agency elects to do so. The failure or refusal of the Local Public Agency to withhold any moneys from the Contractor shall in no wise impair the obligations of any surety or sureties under any bond or bonds furnished under this Contract.

4. Payments Subject to Submission of Certificates

Each payment to the Contractor by the Local Public Agency shall be made subject to submission by the Contractor of all written certifications required of him and his subcontractors by the section entitled CONTRACTOR'S CERTIFICATES under GENERAL CONDITIONS.

109. CHANGES IN THE WORK

- a. The Local Public Agency may make changes in the scope of the work required to be performed by the Contractor under the Contract or making additions thereto, or by omitting work therefrom, without invalidating the Contract, and without relieving or releasing the Contractor from any of his obligations under the Contract or any guarantee given by him pursuant to the Contract provisions, and without affecting the validity of the guaranty bonds, and without relieving or releasing the surety or sureties of said bonds. All such work shall be executed under the terms of the original Contract unless it is expressly provided otherwise.
- b. Except for the purpose of affording protection against any emergency endangering life or property, the Contractor shall make no change in the materials used or in the specified manner of constructing and/or installing the improvements or supply additional labor, services or materials beyond that actually required for the execution of the Contract, unless in pursuance of a written order from the Local Public Agency authorizing the Contractor to proceed with the change. No claim for an adjustment of the Contract Price will be valid unless so ordered.
- c. If applicable unit prices are contained in the Agreement (established as a result of either a unit price bid or a Supplemental Schedule of Unit Prices) the Local Public Agency may order the Contractor to proceed with desired changes in the work, the value of such changes to be determined by the measured quantities involved and the applicable unit prices specified in the Contract; provided that in case of a unit price contract the net value of all changes does not increase or decrease the original total amount shown in the Agreement by more than twenty-five percent (25%) in accordance with the section entitled UNIT PRICES under INSTRUCTIONS TO BIDDERS.
- d. If applicable unit prices are not contained in the Agreement or if the total net change increases or decreases the total Contract Price more than twenty-five percent (25%) the Local Public Agency shall, before ordering the Contractor to proceed with desired changes, request an itemized proposal from him covering the work involved in the change after which the procedure shall be as follows:
 1. If the proposal is acceptable the Local Public Agency will prepare the change order in accordance therewith for acceptance by the Contractor and
 2. If the proposal is not acceptable and prompt agreement between the two parties cannot be reached, the Local Public Agency may order the Contractor to proceed with the work on a cost-plus-limited basis. A cost-plus-limited basis is defined as the net cost of the Contractor's labor, materials and insurance plus fifteen percent (15%) of said net cost to cover overhead and profit, the total cost not to exceed a specified limit.
- e. Each change order shall include in its final form:
 1. A detailed description of the change in the work.
 2. The Contractor's proposal (if any) or a conformed copy thereof.

3. A definite statement as to the resulting change in the contract price and/or time.
4. The statement that all work involved in the change shall be performed in accordance with Contract requirements except as modified by the change order.

110. CLAIMS FOR EXTRA COST

- a. If the Contractor claims that any instructions by Drawings or otherwise involve extra cost or extension of time, he shall, within ten days after the receipt of such instructions, and in any event before proceeding to execute the work, submit his protest thereto in writing to the Local Public Agency, stating clearly and in detail the basis of his objections. No such claim will be considered unless so made.
- b. Claims for additional compensation for extra work, due to alleged errors in ground elevations, contour lines, or bench marks, will not be recognized unless accompanied by certified survey data, made prior to the time the original ground was disturbed, clearly showing that errors exist which resulted, or would result, in handling more material, or performing more work, than would be reasonable estimated from the Drawings and map issued.
- c. Any discrepancies which may be discovered between actual conditions and those represented by the Drawings and maps shall at once be reported to the Local Public Agency and work shall not proceed except at the Contractor's risk, until written instructions have been received by him from the Local Public Agency.
- d. If, on the basis of the available evidence, the Local Public Agency determines that an adjustment of the Contract Price and/or Time is justifiable, the procedure shall be as provided in Section - CHANGE IN THE WORK under GENERAL CONDITIONS, PART I.

111. TERMINATION – DELAYS – LIQUIDATED DAMAGES

- a. Termination of Contract. If the Contractor refuses or fails to prosecute the work with such diligence as will insure its completion within the time specified in these Contract Documents, or as modified as provided in these Contract Documents, the Local Public Agency, by written notice to the Contractor, may terminate the Contractor's right to proceed with the work. Upon such termination, the Local Public Agency may take over the work and prosecute the same to completion, by contract or otherwise, and the Contractor and his sureties shall be liable to the Local Public Agency for liquidated damages for any delay in the completion of the work as provided below. If the Contractor's right to proceed is so terminated, the Local Public Agency may take possession of and utilize in completing the work such materials, tools, equipment, and plans as may be on the site of the work and necessary therefor.
- b. Liquidated Damages for Delays. If the work be not completed within the time stipulated in Section 402 - TIME FOR COMPLETION under SPECIAL CONDITIONS, including any extensions of time for excusable delays as herein provided, the Contractor shall pay to the Local Public Agency as fixed, agreed, and liquidated damages (it being impossible to determine the actual damages occasioned by the delay) for each calendar day of delay, until the work is completed, the amount as set forth in Section 403 - LIQUIDATED DAMAGES under SPECIAL CONDITIONS and the Contractor and his sureties shall be liable to the Local Public Agency for the amount thereof.
- c. Excusable Delays. The right of the Contractor to proceed shall not be terminated nor shall the Contractor be charged with liquidated damages for any delays in the completion of the work due:

1. To any acts of the Government, including controls or restrictions upon or requisitioning of materials, equipment, tools, or labor by reason of war, National Defense, or any other national emergency;
2. To any acts of the Local Public Agency;
3. To causes not reasonably foreseeable by the parties to the Contract at the time of the execution of the Contract which are beyond the control and without the fault or negligence of the Contractor, including, but not restricted to, acts of God or the public enemy, acts of another Contractor in the performance of some other contract with the Local Public Agency, fires, floods, epidemics, quarantine, restrictions, strikes, freight embargoes, and weather of unusual severity such as hurricanes, tornadoes, cyclones and other extreme weather conditions; and
4. To any delay of any subContractor occasioned by any of the causes specified in subparagraphs 1., 2., and 3. of this paragraph "c".

Provided, however, that the Contractor promptly notify the Local Public Agency within ten (10) days in writing of the cause of the delay. Upon receipt of such notification the Local Public Agency shall ascertain the facts and the cause and extent of delay. If, upon the basis of the facts and the terms of this Contract, the delay is properly excusable, the Local Public Agency shall extend the time for completing the work for a period of time commensurate with the period of excusable delay.

112. ASSIGNMENT OR NOVATION

The Contractor shall not assign or transfer, whether by an assignment or novation, any of its rights, duties, benefits, obligations, liabilities, or responsibilities under this contract without the written consent of the Local Public Agency; provided, however, that assignments to banks, trust companies, or other financial institutions may be made without the consent of the Local Public Agency. No assignment or novation of this Contract shall be valid unless the assignment or novation expressly provides that the assignment of any of the Contractor's rights or benefits under the Contract is subject to a prior lien for labor performed, services rendered, and materials, tools, and equipment supplied for the performance of the work under this Contract in favor of all persons, firms, or corporations rendering such labor or services or supplying such materials, tools, or equipment.

113. DISPUTES

- a. All disputes arising under this Contract or its interpretation except those disputes covered by FEDERAL LABOR STANDARDS PROVISIONS under GENERAL CONDITIONS, PART II, whether involving law or fact or both, or extra work, and all claims for alleged breach of contract shall within ten (10) days of commencement of the dispute be presented by the Contractor to the Local Public Agency for decision. All papers pertaining to claims shall be filed in quadruplicate. Such notice need not detail the amount of the claim but shall state the facts surrounding in the claim in sufficient detail to identify the claim, together with its character and scope. In the meantime the Contractor shall proceed with the work as directed. Any claim not presented within the time limit specified this paragraph shall be deemed to have been waived, except that if the claim is of a continuing character and notice of the claim is not given within ten days of its commencement, the claim will be considered only for a period commencing ten (10) days prior to the receipt by the Local Public Agency of notice thereof.
- b. The Contractor shall submit in detail his claim and his proof thereof. Each decision by the governing body of the Local Public Agency will be in writing and will be mailed to the Contractor by registered mail, return receipt requested.

- c. If the Contractor does not agree with any decision of the Local Public Agency, he shall in no case allow the dispute to delay the work but shall notify the Local Public Agency promptly that he is proceeding with the work under protest and he may then except the matter in question from the final release.

114. TECHNICAL SPECIFICATIONS AND DRAWINGS

Anything mentioned in the Technical Specifications and not shown on the Drawings or shown on the Drawings and not mentioned in the Technical Specifications shall be of like effect as if shown on or mentioned in both. In case of difference between Drawings and Technical Specifications, the Technical Specifications shall govern. In case of any discrepancy in Drawings, or Technical Specifications, the matter shall be immediately submitted to the Local Public Agency, without whose decision, said discrepancy shall not be adjusted by the Contractor, save only at his own risk and expense.

115. SHOP DRAWINGS

- a. All required shop Drawings, machinery details, layout Drawings, etc., shall be submitted to the Engineer in two copies for approval sufficiently in advance of requirements to afford ample time for checking, including time for correcting, resubmitting and rechecking if necessary. The Contractor may proceed, only at his own risk, with manufacture or installation of any equipment or work covered by said shop Drawings, etc., until they are approved and no claim, by the Contractor, for extension of the contract time will be granted by reason of his failure in this respect.
- b. Any Drawings submitted without the Contractor's stamp of approval will not be considered and will be returned to him for proper resubmission. If any Drawings show variations from the requirements of the Contract because of standard shop practice or other reason, the Contractor shall make specific mention of such variation in his letter of transmittal in order that, if acceptable, suitable action may be taken for proper adjustment of Contract price and/or time otherwise the Contractor will not be relieved of the responsibility for executing the work in accordance with the Contract even though the Drawings have been approved.
- c. If a shop Drawing is in accord with the contract or involves only a minor adjustment in the interest of the Local Public Agency not involving a change in contract price or time, the Engineer may approve the Drawing. The approval shall be general, shall not relieve the Contractor from his responsibility for adherence to the contract or for any error in the Drawings and shall contain in substance the following:

"The modification shown on the attached Drawing is approved in the interest of the Local Public Agency to effect an improvement for the Project and is ordered with the understanding that it does not involve any change in the Contract Price or time; that it is subject generally to all Contract stipulation and covenants; and that it is without prejudice to any and all rights of the Local Public Agency under the Contract and surety bond or bonds."

116. REQUESTS FOR SUPPLEMENTARY INFORMATION

It shall be the responsibility of the Contractor to make timely requests of the Local Public Agency for any additional information not already in his possession which should be furnished by the Local Public Agency under the terms of this contract, and which he will require in the planning and execution of the work. Such requests may be submitted from time to time as the need is approached, but each shall be filed in ample time to permit appropriate action to be taken by all parties involved so

as to avoid delay. Each request shall be in writing, and list the various items and the latest date by which each will be required by the Contractor. The first list shall be submitted within two weeks after Contract award and shall be as complete as possible at that time. The Contractor shall, if requested, furnish promptly any assistance and information the Engineer may require in responding to these requests of the Contractor. The Contractor shall be fully responsible for any delay in his work or to others arising from his failure to comply fully with the provisions of this Section.

117. MATERIALS AND WORKMANSHIP

- a. Unless otherwise specifically provided for in the Technical Specifications, all workmanship, equipment, materials and articles incorporated in the work shall be new and the best grade of the respective kinds for the purpose. Where equipment, materials, articles or workmanship are referred to in the Technical Specifications as "equal to" any particular standard, the Engineer shall decide the question of equality.
- b. The Contractor shall furnish to the Local Public Agency for approval the manufacturer's detailed specifications for all machinery, mechanical and other special equipment, which he contemplates installing together with full information as to type, performance characteristics, and all other pertinent information as required, and shall likewise submit for approval as required full information concerning all other materials or articles which he proposes to incorporate in the work. (See Section - SAMPLES, CERTIFICATES AND TESTS under GENERAL CONDITIONS, PART I.)
- c. Machinery, mechanical and other equipment, materials or articles installed or used without such prior approval shall be at the risk of subsequent rejection.
- d. Materials specified by reference to the number or symbol of a specific standard, such as an A.S.T.M. Standard, a Federal Specification or other similar standard, shall comply with requirements in the latest revision thereof and any amendment or supplement thereto in effect on the date of the Invitation for Bids, except as limited to type, class or grade, or modified in such reference. The standards referred to, except as modified in the Technical Specifications shall have full force and effect as though printed therein.
- e. The Local Public Agency may require the Contractor to dismiss from the work such employee or employees as the Local Public Agency or the Engineer may deem incompetent, or careless, to insubordinate.

118. SAMPLES, CERTIFICATES, AND TESTS

- a. The Contractor shall submit all material or equipment samples, certificates, affidavits, etc., as called for in the contract documents or required by the Engineer, promptly after award of the contract and acceptance of the Contractor's bond. No such material or equipment shall be manufactured or delivered to the site, except at the Contractor's own risk, until the required samples or certificates have been approved in writing by the Engineer. Any delay in the work caused by late or improper submission of samples or certificates for approval shall not be considered just cause for an extension of the contract time.

Each sample submitted by the Contractor shall carry a label giving the name of the Contractor, the project for which it is intended, and the name of the producer. The accompanying certificate or letter from the Contractor shall state that the sample complies with contract requirements, shall give the name and brand of the product, its place of origin, the name and address of the producer and all specifications or other detailed information which will assist the Engineer in passing upon the acceptability of the sample promptly. It shall also include the statement that all materials or

equipment furnished for use in the project will comply with the samples and/or certified statements.

- b. Approval of any materials shall be general only and shall not constitute a waiver of the Local Public Agency's right to demand full compliance with Contract requirements. After actual deliveries, the Engineer will have such check tests made as he deems necessary in each instance and may reject materials and equipment and accessories for cause, even though such materials and articles have been given general approval. If materials, equipment or accessories which fail to meet check tests have been incorporated in the work, the Engineer will have the right to cause their removal and replacement by proper materials or to demand and secure such reparation by the Contractor as is equitable.
- c. Except as otherwise specifically stated in the Contract, the costs of sampling and testing will be divided as follows:
 - (1) The Contractor shall furnish without extra cost, including packing and deliver charges, all samples required for testing purposes, except those samples taken on the project by the Engineer;
 - (2) The Contractor shall assume all costs of re-testing materials which fail to meet Contract requirements;
 - (3) The Contractor shall assume all costs of testing materials offered in substitution for those found deficient; and
 - (4) The Local Public Agency will pay all other expenses.

119. PERMITS AND CODES

- a. The Contractor shall give all notices required by and comply with all applicable laws, ordinances, and codes of the Local Government. All construction work and/or utility installations shall comply with all applicable ordinances, and codes including all written waivers. Before installing any work, the Contractor shall examine the Drawings and Technical Specifications for compliance with applicable ordinances and codes and shall immediately report any discrepancy to the Local Public Agency. Where the requirements of the Drawings and Technical Specifications fail to comply with such applicable ordinances or codes, the Local Public Agency will adjust the Contract by Change Order to conform to such ordinance or codes (unless waivers in writing covering the difference have been granted by the governing body or department) and make appropriate adjustment in the Contract price or stipulated unit prices.

Should the Contractor fail to observe the foregoing provisions and proceed with the construction and/or install any utility at variance with any applicable ordinance or code, including any written waivers (notwithstanding the fact that such installation is in compliance with the Drawings and Technical Specifications), the Contractor shall remove such work without cost to the Local Public Agency, but a Change Order will be issued to cover only the excess cost the Contractor would have been entitled to receive if the change had been made before the Contractor commenced work on the items involved.

- b. The Contractor shall at his own expense, secure and pay to the appropriate department of the Local Government the fees or charges for all permits for street pavement, sidewalks, sheds, removal of abandoned water taps, sealing of house connection drains, pavements cuts, buildings, electrical, plumbing, water, gas and sewer permits required by the local regulatory body or any of its agencies.

- c. The Contractor shall comply with applicable local laws and ordinances governing the disposal of surplus excavation, materials debris and rubbish on or off the Project Area and commit no trespass on any public or private property in any operation due to or connected with the Improvements embraced in this Contract.

120. CARE OF WORK

- a. The Contractor shall be responsible for all damages to person or property that occur as a result of his fault or negligence in connection with the prosecution of the work and shall be responsible for the proper care and protection of all materials delivered and work performed until completion and final acceptance, whether or not the same has been covered in whole or in part by payments made by the Local Public Agency.
- b. The Contractor shall provide sufficient competent watchmen, both day and night, including Saturdays, Sundays and holidays, from the time the work is commenced until final completion and acceptance.
- c. In an emergency affecting the safety of life or property, including adjoining property, the Contractor, without special instructions or authorization from the Local Public Agency, is authorized to act at his discretion to prevent such threatened loss or injury, and he shall so act. He shall likewise act if instructed to do so by the Local Public Agency. Any compensation claimed by the Contractor on account of such emergency work will be determined by the Local Public Agency as provided in the Section - CHANGES IN THE WORK under GENERAL CONDITIONS, PART I.
- d. The Contractor shall avoid damage as a result of his operations to existing sidewalks, streets, curbs, pavements, utilities (except those which are to be replaced or removed), adjoining property, etc., and he shall at his own expense completely repair any damage thereto caused by his operations.
- e. The Contractor shall shore up, brace, underpin, secure, and protect as may be necessary, all foundations and other parts of existing structures adjacent to, adjoining, and in the vicinity of the site, which may be in any way affected by the excavations or other operations connected with the construction of the Improvements embraced in this Contract. The Contractor shall be responsible for the giving of any and all required notices to any adjoining or adjacent property owner or other party before the commencement of any work. The Contractor shall indemnify and save harmless the Local Public Agency from any damages on account of settlements or the loss of lateral support of adjoining property and from all loss or expense and all damages for which the Local Public Agency may become liable in consequence of such injury or damage to adjoining and adjacent structures and their premises.

121. ACCIDENT PREVENTION

- a. The Contractor shall exercise proper precaution at all times for the protection of persons and property and shall be responsible for all damages to persons or property, either on or off the site, which occur as a result of his prosecution of the work. The safety provisions of applicable laws and building and construction codes shall be observed and the Contractor shall take or cause to be taken such additional safety and health measures as the Local Public Agency may determine to be reasonably necessary. Machinery, equipment and all hazards shall be guarded in accordance with the safety provisions of the *"Manual of Accident Prevention in Construction"* published by the Associated General Contractors of America, Inc., to the extent that such provisions are not in conflict with applicable local laws.
- b. The Contractor shall maintain an accurate record of all cases of death, occupational disease, and injury requiring medical attention or causing loss of time from work, arising out of and in the course of employment on work under the Contract. The Contractor shall promptly furnish the Local Public Agency with reports concerning these matters.

- c. The Contractor shall indemnify and save harmless the Local Public Agency from any claims for damages resulting from personal injury and/or death suffered or alleged to have been suffered by any person as a result of any work conducted under this Contract.

122. SANITARY FACILITIES

The Contractor shall furnish, install, and maintain ample sanitary facilities for the workmen. As the needs arise, a sufficient number of enclosed temporary toilets shall be conveniently placed as required by the sanitary codes of the State and Local Government. Drinking water shall be provided from an approved source, so piped or transported as to keep it safe and fresh and served from single service containers or satisfactory types of sanitary drinking stands or fountains. All such facilities and services shall be furnished in strict accordance with existing and governing health regulations.

123. USE OF PREMISES

- a. The Contractor shall confine his equipment, storage of materials, and construction operations to the Contract limits as shown on the Drawings and as prescribed by ordinances or permits, or as may be desired by the Local Public Agency, and shall not unreasonably encumber the site or public rights of way with his materials and construction equipment.
- b. The Contractor shall comply with all reasonable instructions of the Local Public Agency and the ordinances and codes of the Local Government, regarding signs, advertising, traffic, fires, explosives, danger signals, and barricades.

124. REMOVAL OF DEBRIS, CLEANING, ETC.

The Contractor shall, periodically or as directed during the progress of the work, remove and legally dispose of all surplus excavated material and debris, and keep the Project Area and public rights of way reasonably clear. Upon completion of the work, he shall remove all temporary construction facilities, debris and unused materials provided for the work, and put the whole site of the work and public rights of way in a neat and clean condition. Trash burning on the site of the work will be subject to prior approval of the Local Public Agency and existing State and Local regulations.

125. INSPECTION

- a. All materials and workmanship shall be subject to inspection, examination, or test by the Local Public Agency and the Engineer at any and all times during manufacture or construction and at any and all places where such manufacture or construction is carried on. The Local Public Agency shall have the right to reject defective material and workmanship or require its correction. Unacceptable workmanship shall be satisfactorily corrected. Rejected material shall be promptly segregated and removed from the Project Area and replaced with material of specified quality without charge therefore. If the Contractor fails to proceed at once with the correction of rejected workmanship or defective material, the Local Public Agency may contract or otherwise have the defects remedied, or rejected materials removed from the Project Area and charge the cost of the same against any moneys which may be due the Contractor, without prejudice to any other rights or remedies of the Local Public Agency.
- b. The Contractor shall furnish promptly all materials reasonably necessary for any tests which may be required. (See Section - SAMPLES, CERTIFICATES AND TESTS, under the GENERAL CONDITIONS, PART I.) All tests by the Local Public Agency will be performed in such manner as not to delay the work unnecessarily and shall be made in the Technical Specifications.

- c. The Contractor shall notify the Local Public Agency sufficiently in advance of backfilling or concealing any facilities to permit proper inspection. If any facilities are concealed without approval or consent of the Local Public Agency, the Contractor shall uncover for inspection and recover such facilities all at his own expense, when so requested by the Local Public Agency.

Should it be necessary or advisable by the Local Public Agency at any time before final acceptance of the entire work to make an examination of work already completed, by uncovering the same, the Contractor shall, on request, promptly furnish all necessary facilities, labor, and material. If such work is found to be defective in any important or essential respect, due to fault of the Contractor or his subcontractors shall defray all the expenses of such examination and of satisfactory re-construction. If, however, such work is found to meet the requirements of the Contract, the actual cost of labor and material necessarily involved in the examination and replacement, plus 15 percent of such costs to cover superintendence, general expenses and profit, shall be allowed the Contractor and he shall, in addition of completion of the work of the entire Contract has been delayed thereby, be granted a suitable extension of time on account of the additional work involved.

- d. Inspection of materials and appurtenances to be incorporated in the Improvements embraced in this Contract may be made at the place of production, manufacture or shipment, whenever the quantity justifies it, and such inspection and acceptance, unless otherwise stated in the Technical Specifications, shall be final except as regards (1) latent defects, (2) departures from specific requirements of the Contract, (3) damage or loss in transit, or (4) fraud or such gross mistakes as amount to fraud.

Subject to the requirements contained in the preceding sentence, the inspection of materials as a whole or in part will be made at the Project Site.

- e. Neither inspection, testing, approval nor acceptance of the work in whole or in part, by the Local Public Agency or its agents shall relieve the Contractor or his sureties of full responsibility for material furnished or work performed not in strict accordance with the Contract.
- f. Any work performed within the right-of-way of any Pennsylvania Department of Transportation highway, roadway or travel way shall be subject to inspection by a representative of the Pennsylvania Department of Transportation. It shall be the responsibility of the Local Government to reimburse the Pennsylvania Department of Transportation for any and all such inspection services.

126. REVIEW BY LOCAL PUBLIC AGENCY

The Local Public Agency, its authorized representatives and agents and the HUD Representative for the Administrator (as defined under GENERAL CONDITIONS, PART II) shall, at all times have access to and be permitted to observe and review all work, materials, equipment, payrolls, personnel records, employment conditions, material invoices, and other relevant data and records pertaining to this Contract, provided, however, that all instructions and approval with respect to the work will be given to the Contractor only by the Local Public Agency through its authorized representatives or agents.

127. FINAL INSPECTION

- a. When the Improvements embraced in this Contract are substantially completed, the Contractor shall notify the Local Public Agency, in writing, that the work will be ready for final inspection on a definite date which shall be stated in the notice. The notice will be given at least ten (10) days prior to the date stated for final inspection, and bear the signed concurrence of the representative of the Local Public Agency having charge of inspection. If the Local Public Agency determines that the status of the Improvements is as represented, it will make the arrangements necessary to have final inspection commenced on the date stated in the notice, or as soon thereafter as is practicable. The inspection party will also include the HUD Representative and representatives of each department of the Local Government having in charge improvements of like character when such Improvements are later to be accepted by the Local Government.

128. DEDUCTION FOR UNCORRECTED WORK

If the Local Public Agency deems it not expedient to require the Contractor to correct work not done in accordance with the Contract Documents, an equitable deduction from the Contract Price will be made by agreement between the Contractor and the Local Public Agency and subject to settlement, in case of dispute, as herein provided.

129. INSURANCE

- a. The Contractor shall carry or require that there be carried Workmen's Compensation Insurance for all his employees and those of his subcontractors engaged in work at the site, in accordance with State or Territorial Workmen's Compensation Laws.
- b. The Contractor shall carry or require that there be carried Manufacturer's and Contractor's Public Liability Insurance with limits of \$500,000 bodily injury each person - \$500,000 each occurrence to protect the Contractor and his subcontractors against claims for injury to or death of one, or more than one, person, because of accidents which may occur or result from operations under the Contract; such insurance shall cover the use of all equipment, including but not limited to excavating machinery, trenching machines, cranes, hoists, rollers, concrete mixers, and motor vehicles, in the construction of the Improvements embraced in this Contract.
- c. The Contractor shall carry, during the life of the Contract, Property Damage Insurance in an amount not less than \$500,000 to protect him and his subcontractors from claims for property damage which might arise from operations under the Contract.
- d. Before commencing work, the Contractor shall submit evidence of the coverage required above to the Local Public Agency for review and approval. The policies shall be scheduled on a form approved by the Local Public Agency. The Local Public Agency will, in writing, identify the policies and indicate its approval or disapproval. New policies from other companies shall be provided in place of those disapproved. Such insurance shall be carried with financially responsible insurance companies, licensed in the State and approved by the Local Public Agency, and shall be kept in force until the Contractor's work is accepted by the Local Public Agency. Contracts of insurance (covering all operations under this Contract) which expire before the Contractor's work is accepted by the Local Public Agency shall be renewed and evidence submitted to the Local Public Agency for its approval.

130. PATENTS

The Contractor shall hold and save the Local Public Agency, its officers, and employees, harmless from liability of any nature or kind, including costs and expenses for or on account of, any patented or unpatented invention, process, article, of appliance manufactured or used in the performance of the Contract, including its use by the Local Public Agency, unless otherwise specifically stipulated in the Technical Specifications.

131. WARRANTY OF TITLE

No material, supplies, or equipment for the work shall be purchased subject to any chattel mortgage or under a conditional sale or other agreement by which an interest therein or in any part thereof is retained by the seller or supplier. The Contractor shall warrant good title to all materials, supplies, and equipment installed or incorporated in the work and upon completion of all work, shall deliver the same together with all improvements and appurtenances constructed or placed thereon by him to the Local Public Agency free from any claims, liens, or charges. Neither the Contractor nor any person, firm or corporation furnishing any material or labor for any work covered by this Contract shall have any right to a lien upon any improvement or appurtenance thereon. Nothing contained in this paragraph, however, shall defeat or impair the right of persons furnishing materials or labor to recover under any bond given by the Contractor for their protection or any rights under any law permitting such persons to look to funds due the Contractor in the hands of the Local Public Agency. The provisions of this paragraph shall be inserted in all subcontracts and material contracts and notice of its provisions shall be given to all persons furnishing materials for the work when no formal contract is entered into for such materials.

132. GENERAL GUARANTY

Neither the final certificate of payment nor any provision in the Contract nor partial or entire use of the Improvements embraced in this Contract by the Local Public Agency or the public shall constitute an acceptance of work not done in accordance with the Contract or relieve the Contractor of liability in respect to any express warranties or responsibility for faulty materials or workmanship. The Contractor shall promptly remedy any defects in the work and pay for any damage to other work resulting therefrom which shall appear within a period of twelve months from the date of final acceptance of the work. The Local Public Agency will give notice of defective materials and work with reasonable promptness.

THIS PAGE INTENTIONALLY LEFT BLANK

**GENERAL CONDITIONS
PART II
FEDERAL REQUIREMENTS**

All bidders must comply with the following Federal requirements:

I. TITLE VI OF THE CIVIL RIGHTS ACT OF 1964 (P.L. 88-352) AS STATED IN 24 CFR 570.496.

“No person in the United States shall on the grounds of race, color, national origin, or sex be excluded from participation in, be denied the benefits of, or be subjected to discrimination under any program or activity funded in whole or in part with funds made available under this Title.”

II. EXECUTIVE ORDER 11063, AS AMENDED.

“No person in the United States shall on the basis of race, color, religion, sex, or national origin, be discriminated against in housing (and related facilities) provided with Federal assistance and in lending practices with respect to residential property when such practices are connected with loans insured or guaranteed by the Federal Government.”

III. EXECUTIVE ORDER 11246.

A. If the contract amount is less than \$10,000 the following conditions shall apply:

During the performance of this contract the Contractor agrees as follows:

- (1) The Contractor will not discriminate against any employee or applicant for employment because of race, color, religion, sex, or national origin. The Contractor will take affirmative action to ensure that applicants are employed, and that employees are treated during employment without regard to their race, color, religion, sex, or national origin. Such actions shall include, but not be limited to, the following: Employment, upgrading, demotion, or transfer; recruitment or recruitment advertising; layoff or termination; rates of pay or other forms of compensation; and selection for training, including apprenticeship. The Contractor agrees to post in conspicuous places, available to employees and applicants for employment, notices to be provided by the Local Public Agency setting forth the provisions of this nondiscrimination clause.
- (2) The Contractor will, in all solicitation or advertisements for employees placed by or on behalf of the Contractor, state that all qualified applicants will receive consideration for employment without regard to race, color, religion, sex, or national origin.
- (3) The Contractor will cause the foregoing provisions to be inserted in all subcontracts for any work covered by this contract so that such provisions will be binding upon each subcontractor, provided that the foregoing provisions shall not apply to contracts or subcontracts for standard commercial supplies or raw materials.

B. If the contract amount exceeds \$10,000 the following conditions shall apply:

- (1) The Contractor will not discriminate against any employee or applicant for employment because of race, color, religion, sex, or national origin. The Contractor will take affirmative action to ensure that applicants are employed, and that employees are treated during employment without regard to their race, color, religion, sex, or national origin. Such action shall include, but not be limited to the following:

Employment, upgrading, demotion, or transfer; recruitment or recruitment advertising; layoff or termination; rates of pay or other forms of compensation; and selection for training, including apprenticeship. The Contractor agrees to post in conspicuous places, available to employees and applicants for employment, notices to be provided setting forth the provisions of this nondiscrimination clause.

- (2) The Contractor will, in all solicitations or advertisements for employees placed by or on behalf of the Contractor, state that all qualified applicants will receive consideration for employment without regard to race, color, religion, sex, or national origin.
- (3) The Contractor will send to each labor union or representative of workers with which he has a collective bargaining agreement or other contract or understanding, a notice to be provided advising the said labor union or worker's representatives of the Contractor's commitments under this section, and shall post copies of the notice in conspicuous places available to employees and applicants for employment.
- (4) The Contractor will comply with all provisions of Executive Order 11246 of September 24, 1965; and the rules, regulations and relevant orders of the Secretary of Labor.
- (5) The Contractor will furnish all information and reports required by Executive Order 11246 of September 24, 1965, and rules, regulations and orders of the Secretary of Labor, or pursuant thereto, and will permit access to his books, records, and accounts by the Contracting Agency and the Secretary of Labor for purposes of investigation to ascertain compliance with such rules, regulations and orders.
- (6) In the event of the Contractor's noncompliance with the nondiscrimination clauses of this contract or with any of the said rules, regulations, or orders, this contract may be canceled, terminated, or suspended in whole or in part and the Contractor may be declared ineligible for further Government contracts or federally assisted construction contracts in accordance with procedures authorized in Executive Order 11246 of September 24, 1965, and such other sanctions may be imposed and remedies invoked as provided in Executive Order 11246 of September 24, 1965, or by rule, regulations, or order of the Secretary of Labor, or as otherwise provided by law.
- (7) The Contractor will include the portion of the sentence immediately preceding paragraph (B-1) and the provisions of paragraphs (B-1) through (B-7) in every subcontract or purchase order unless exempted by rules, regulations, or orders of the Secretary of Labor issued pursuant to Section 204 of Executive Order 11246 of September 24, 1965, so that such provisions will be binding upon each subcontractor or vendor. The Contractor will take such action with respect to any subcontract or purchase order as the Contracting Agency may direct as a means of enforcing such provisions, including sanctions for noncompliance: Provided, however, that in the event a Contractor becomes involved in, or is threatened with, litigation with a subcontractor or vendor as a result of such direction by the Contracting Agency, the Contractor may request the United States to enter into such litigation to protect the interests of the United States.

**NOTICE OF REQUIREMENT FOR AFFIRMATIVE ACTION TO ENSURE
EQUAL EMPLOYMENT OPPORTUNITY (EXECUTIVE ORDER 11246)**

1. The Offeror's or Bidder's attention is called to the "Equal Opportunity Clause" and the "Standard Federal Equal Employment Opportunity Construction Contract Specifications" set forth herein.
2. The goals and timetables for minority and female participation, expressed in percentage terms for the Contractor's aggregate work force in each trade on all construction work in the covered area, are as follows:

Goals and Timetables
for Minority Participation
for Each Trade
5% - Until further notice

Goals and Timetables for Female
Participation in
Each Trade
3% - Until further notice

These goals are applicable to all the Contractor's construction work (whether or not it is Federal or federally assisted) performed in the covered area.

The Contractor's compliance with the Executive Order and the regulations in 41 CFR Part 60-4 shall be based on its implementation of the Equal Opportunity Clause, specific affirmative action obligations required by the specifications set forth in 41 CFR 60-4.3(a), and its efforts to meet the goals established for the geographical area where the contract resulting from this solicitation is to be performed. The hours of minority and female employment and training must be substantially uniform throughout the length of the contract, and in each trade, and the Contractor shall make a good faith effort to employ minorities and women evenly on each of its projects. The transfer of minority or female employees or trainees from Contractor to Contractor or from project to project for the sole purpose of meeting the Contractor's goals shall be a violation of the contract, the Executive Order and the regulations in 41 CFR Part 60-4. Compliance with the goals will be measured against the total work hours performed.

3. The Contractor shall provide written notification to the Director of the Office of Federal Contract Compliance Programs within 10 working days of award of any construction subcontract in excess of \$10,000 at any tier for construction work under the contract resulting from this solicitation. The notification shall list the name, address, and telephone number of the subcontractor; employer identification number; estimated dollar amount of the subcontract; estimated starting and completion dates of the subcontract; and the geographical area in which the contract is to be performed.
4. As used in this Notice, and in the contract resulting from this solicitation, the "covered area" is (insert description of the geographical areas where the contract is to be performed giving the state, county and city, if any).

**STANDARD FEDERAL EQUAL EMPLOYMENT
OPPORTUNITY CONSTRUCTION CONTRACT SPECIFICATIONS
(EXECUTIVE ORDER 11246)**

1. As used in these specifications:
 - a. “Covered area” means the geographical area described in the solicitation from which this contract resulted;
 - b. “Director” means Director, Office of Federal Contract Compliance Programs, United States Department of Labor, or any person to whom the Director delegates authority;
 - c. “Employer Identification Number” means the Federal Social Security number used on the Employer’s Quarterly Federal Tax Return, U.S. Treasury Department Form 941.
 - d. “Minority” includes:
 - (i) Black (all persons having origins in any of the Black African racial groups not of Hispanic origin);
 - (ii) Hispanic (all persons of Mexican, Puerto Rican, Cuban, Central or South American or other Spanish Culture or origin, regardless of race);
 - (iii) Asian and Pacific Islander (all persons having origins in any of the original peoples of the Far East, Southeast Asia, and the Indian Subcontinent, or the Pacific Islands); and
 - (iv) American Indian or Alaskan Native (all persons having origins in any of the original peoples of North America and maintaining identifiable affiliations through membership and participation or community identification).
2. Whenever the Contractor, or any Subcontractor at any tier, subcontracts a portion of the work involving any construction trade, it shall physically include in each subcontract in excess of \$10,000 the provisions of these specifications and the Notice which contains the applicable goals for minority and female participation and which is set forth in the solicitations from which this contract resulted.
3. If the Contractor is participating (pursuant to 41 CFR 60-4.5) in a hometown Plan approved by the U.S. Department of Labor in the covered area either individually or through an association, its affirmative action obligations on all work in the Plan area (including goals and timetables) shall be in accordance with that Plan for those trades which have unions participating in the Plan. Contractors must be able to demonstrate their participation in and compliance with the provisions of any such Hometown Plan. Each Contractor or Subcontractor participating in an approved Plan is individually required to comply with its obligations under the EEO Clause, and to make a good faith effort to achieve each goal under the Plan in each trade in which it has employees. The overall good faith performance by other Contractors or Subcontractors toward a goal in an approved Plan does not excuse any covered Contractor’s or Subcontractor’s failure to take good faith efforts to achieve the Plan goals and timetables.
4. The Contractor shall implement the specific affirmative action standards provided in paragraphs 7a through p of these specifications. The goals set forth in the solicitation from which this contract resulted are expressed as percentages of the total hours of employment and training of minority and female utilization, the Contractor should reasonably be able to achieve in each construction trade in

which it has employees in the covered area. The Contractor is expected to make substantially uniform progress toward its goals in each craft during the period specified.

5. Neither the provisions of any collective bargaining agreement, nor the failure by a union with whom the Contractor has a collective bargaining agreement, to refer either minorities or women shall excuse the Contractor's obligations under these specifications, Executive Order 11246, or the regulations promulgated pursuant thereto.
6. In order for the nonworking training hours of apprentices and trainees to be counted in meeting the goals, such apprentices and trainees must be employed by the Contractor during the training period, and the Contractor must have made a commitment to employ the apprentices and trainees at the completion of their training, subject to the availability of employment opportunities. Trainees must be trained pursuant to training programs approved by the U.S. Department of Labor.
7. The Contractor shall take specific affirmative actions to ensure equal employment opportunity. The evaluation of the Contractor's compliance with these specifications shall be based upon its effort to achieve maximum results from its actions. The Contractor shall document these efforts fully, and shall implement affirmative action steps at least as extensive as the following:
 - a. Ensure and maintain a working environment free of harassment, intimidation, and coercion at all sites, and in all facilities at which the Contractor's employees are assigned to work. The Contractor where possible, will assign two or more women to each construction project. The Contractor shall specifically ensure that all foremen, superintendents, and other on-site supervisory personnel are aware of and carry out the Contractor's obligation to maintain such a working environment, with specific attention to minority or female individuals working at such sites or in such facilities.
 - b. Establish and maintain a current list of minority and female recruitment sources, provide written notification to minority and female recruitment sources and to community organizations when the Contractor or its unions have employment opportunities available, and maintain a record of the organizations' responses.
 - c. Maintain a current file of names, addresses and telephone numbers of each minority and female offstreet applicant and minority or female referral from a union, a recruitment source or community organization and of what action was taken with respect to each such individual. If such individual was sent to the union hiring hall for referral and was not referred back to the Contractor by the union or referred, not employed by the Contractor, this shall be documented in the file with the reason thereafter, along with whatever additional actions the Contractor may have taken.
 - d. Provide immediate written notification to the Director when the union or unions with which the Contractor has a collective bargaining agreement has not referred to the Contractor a minority person or woman sent by the Contractor, or when the Contractor has other information that the union referral process has impeded the Contractor's efforts to meet its obligation.
 - e. Develop on-the-job training opportunities and/or participate in training programs for the area which expressly include minorities and women, including upgrading programs and apprenticeship and trainee programs relevant to the Contractor's employment needs, especially those programs funded or approved by the Department of Labor. The Contractor shall provide notice of these programs to the sources compiled under 7b above.

- f. Disseminate the Contractor's EEO policy by providing notice of the policy to unions and training programs and requesting their cooperation in assisting the Contractor in meeting its EEO obligations; by including it in any policy manual and collective bargaining agreement; by publicizing it in the company newspaper, annual report, etc.; by specific review of the policy with all management personnel and with all minority and female employees at least once a year; and by posting the company EEO policy on bulletin boards accessible to all employees at each location where construction work is performed.
- g. Review, at least annually, the company's EEO policy and affirmative action obligations under these specifications with all employees having any responsibility for hiring, assignment, layoff, termination or other employment decisions including specific review of these items with on-site supervisory personnel such as Superintendents, General Foreman, etc., prior to the initiation of construction work at any job site. A written record shall be made and maintained identifying the time and place of these meetings, persons attending, subject matter discussed, and in disposition of the subject matter.
- h. Disseminate the Contractor's EEO policy externally by including it in any advertising in the news media, specifically including minority and female news media, and providing written notification to and discussing the Contractor's EEO policy with other Contractors and Subcontractors with whom the Contractor does or anticipates doing business.
- i. Direct its recruitment efforts, both oral and written, to minority, female and community organizations, to schools with minority and female students and to minority and female recruitment and training organizations serving the Contractor's recruitment area and employment needs. Not later than one month prior to the date for the acceptance of applications for apprenticeship or other training by any recruitment sources, the Contractor shall send written notification to organizations such as the above, describing the openings, screening procedures, and tests to be used in the selection process.
- j. Encourage present minority and female employees to recruit other minority persons and women, and where reasonable, provide after school, summer and vacation employment to minority and female youth both on the site and in other areas of a Contractor's workforce.
- k. Validate all tests and other selection requirements where there is an obligation to do so under 41 CFR Part 60-3.
- l. Conduct, at least annually, an inventory and evaluation at least of all minority and female personnel for promotional opportunities and encourage these employees to seek or to prepare for, through appropriate training, etc. such opportunities.
- m. Ensure that seniority practices, job classifications, work assignments and other personnel practices, do not have a discriminatory effect by continually monitoring all personnel and employment related activities to ensure that the EEO policy and the Contractor's obligations under these specifications are being carried out.
- n. Ensure that all facilities and company activities are nonsegregated except that separate or single-user toilet and necessary changing facilities shall be provided to assure privacy between the sexes.
- o. Document and maintain a record of all solicitation of offers for subcontracts from minority and female construction contractors and suppliers, including circulation of solicitations to minority and female contractor associations and other business associations.

- p. Conduct a review, at least annually, of all supervisors' adherence to and performance under the Contractor's EEO policies and affirmative action obligations.
8. Contractors are encouraged to participate in voluntary associations which assist in fulfilling one or more of their affirmative action obligations (7a through p). The efforts of a contractor association, joint contractor-union, contractor-community, or other similar group of which the Contractor is a member and participant, may be asserted as fulfilling any one or more of its obligations under 7a through p of these Specifications provided that the Contractor actively participates in the group, makes every effort to assure that the group has a positive impact on the employment of minorities and women in the industry, ensures that the concrete benefits of the program are reflected in the Contractor's minority and female workforce participation, makes a good effort to meet its individual goals and timetables, and can provide access to documentation which demonstrates the effectiveness of actions taken on behalf of the Contractor. The obligation to comply, however, is the Contractor's and failure of such a group to fulfill an obligation shall not be a defense for the Contractor's noncompliance.
9. A single goal for minorities and a separate single goal for women have been established. The Contractor, however, is required to provide equal employment opportunity and to take affirmative action for all minority groups, both male and female, and all women, both minority and nonminority. Consequently, the Contractor may be in violation of the Executive Order if a particular group is employed in a substantially disparate manner (for example, even though the Contractor has achieved its goals for women generally, the Contractor may be in violation of the Executive Order if a specific minority group of women is underutilized).
10. The Contractor shall not use the goals and timetables or affirmative action standards to discriminate against any person because of race, color, religion, sex, or national origin.
11. The Contractor shall not enter into any Subcontract with any person or firm debarred from Government contracts pursuant to Executive Order 11246.
12. The Contractor shall carry out such sanctions and penalties for violation of these specifications and of the Equal Opportunity Clause, including, suspension, termination and cancellation of existing Subcontracts as may be imposed or ordered pursuant to Executive Order 11246 as amended, and its implementing regulations by the Office of Federal Contract Compliance Programs. Any Contractor who fails to carry out such sanctions and penalties shall be in violation of these specifications and Executive Order 11246, as amended.
13. The Contractor, in fulfilling its obligations under these specifications, shall implement specific affirmative action steps, at least as extensive as those standards prescribed in paragraph 7 of these specifications, so as to achieve maximum results from its efforts to ensure equal employment opportunity. If the Contractor fails to comply with the requirements of the Executive Order, the implementing regulations, or these specifications, the Director shall proceed in accordance with 41 CFR 60-4-8.
14. The Contractor shall designate a responsible official to monitor all employment related activity to ensure that the company EEO policy is being carried out, to submit reports relating to the provisions hereof as may be required by the Government and to keep records. Records shall at least include for each employee the name, address, telephone numbers, construction trade, union affiliation, if any, employee identification number when assigned, social security number, race, sex, status (e.g. mechanic, apprentice, trainee, helper, or laborer), dates of changes in status, hours worked per week in the indicated trade, rate of pay, and locations at which the work was performed. Records shall be maintained in an easily understandable and retrievable form; however, to the degree that existing records satisfy this requirement, contractors shall not be required to maintain separate records.

15. Nothing herein provided shall be construed as a limitation upon the application of other laws which establish different standards of compliance or upon the application or requirements for the hiring of local or other area residents (e.g. those under the Public Works Employment Act of 1977 and the Small Communities Program).

IV. CONTRACT WORK HOURS AND SAFETY STANDARDS ACT (40 U.S.C. 327 ET SEQ.)

The Contractor, if the contract is in excess of \$2,000, and any of his subcontractors, shall comply with Section 103 and 107 of the Contract Work Hours and Safety Standards Act (40 U.S.C. 327-330) as supplemented by Department of Labor Regulations contained in 29 CFR Part 5.

Specific provisions of these sections are more fully described in Section 5, Federal Labor Standards Provisions, Subsection 3, Contract Work Hours and Safety Standards Act, below.

V. FEDERAL LABOR STANDARDS PROVISIONS

Pennsylvania Department of Community and Economic Development Program

1. Applicability

The Project or Program to which the work covered by this Contract pertains is being assisted by the Pennsylvania Small Communities Program and the following Federal Labor Standards Provisions are included in this Contract pursuant to the provisions applicable to such Federal assistance.

2. Minimum Wage Rates for Laborers and Mechanics

A. Minimum Wages.

All laborers and mechanics employed or working upon the site of the work will be paid unconditionally and not less often than once a week and without subsequent deduction or rebate on any account (except such payroll deductions as are permitted by regulations issued by the Secretary of Labor under the Copeland Act [29 CFR Part 3]), the full amount of wages and bona fide fringe benefits (or cash equivalents thereof) due at time of payment computed at rates not less than those contained in the wage determination of the Secretary of Labor which is attached hereto and made a part hereof, regardless of any contractual relationship which may be alleged to exist between the Contractor and such laborers and mechanics. Contributions made or costs reasonably anticipated for bona fide fringe benefits under Section 1(b)(2) of the Davis-Bacon Act on behalf of laborers or mechanics are considered wages paid to such laborers or mechanics, subject to the provisions of 29 CFR 5.5(a)(1)(iv); also, regular contributions made or costs incurred for more than a weekly period (but not less than quarterly) under plans, funds, or programs, which cover the particular weekly period, are deemed to be constructively made or incurred during such weekly period.

Such laborers and mechanics shall be paid the appropriate wage rate and fringe benefits on the wage determination for the classification of work actually performed, without regard to skill, except as provided in 29 CFR Part 5.5(a)(4). Laborers or mechanics performing work in more than one classification may be compensated at the rate specified for each classification for the time actually worked therein; provided, that the employer's payroll records accurately set forth the time spent in

each classification in which work is performed. The wage determination (including any additional classification and wage rates conformed under 29 CFR Part 5.5(a)(1)(ii) and the Davis-Bacon poster (WH-1321) shall be posted at all times by the Contractor and its subcontractors at the site of the work in a prominent and accessible place where it can be easily seen by the workers.

Any class of laborers or mechanics which is not listed in the wage determination and which is to be employed under the contract shall be classified in conformance with the wage determination. DCED shall approve an additional classification and wage rate and fringe benefits therefore only when the following criteria have been met:

- (1) The work to be performed by the classification requested is not performed by a classification in the wage determination; and
- (2) The classification is utilized in the area by the construction industry; and
- (3) The proposed wage rate, including any bona fide fringe benefits, bears a reasonable relationship to the wage rates contained in the wage determination.

If the Contractor and the laborers and mechanics to be employed in the classification (if known), or their representatives, and DCED or its designee agree on the classification and wage rate (including the amount designated for fringe benefits where appropriate) a report of the action taken shall be sent by DCED or its designee to the Administrator of the Wage and Hour Division, Employment Standards Administration, U.S. Department of Labor, Washington D.C. 20210. The Administrator, or an authorized representative, will approve, modify, or disapprove every additional classification action within 30 days of receipt and so advise DCED or its designee within the 30-day period that additional time is necessary.

In the event the Contractor, the laborers or mechanics to be employed in the classification or their representatives, and DCED or its designee do not agree on the proposed classification and wage rate (including the amount designated for fringe benefits, where appropriate), DCED or its designee shall refer the questions, including the views of all interested parties and the recommendations of DCED or its designee, to the Administrator for determination. The Administrator, or an authorized representative, will issue a determination within 30 days of receipt and so advise DCED or its designee within the 30-day period that additional time is necessary.

The wage rate (including fringe benefits where appropriate) determined pursuant to paragraphs 4 and 5 of this Section (**Minimum Wages**), shall be paid to all workers performing work in the classification under this contract from the first day on which work is performed in the classification.

Whenever the minimum wage rate prescribed in the contract for a class of laborers or mechanics includes a fringe benefit which is not expressed as an hourly rate, the Contractor shall either pay the benefit as stated in the wage determination or shall pay another bona fide fringe benefit or an hourly cash equivalent thereof.

If the Contractor does not make payments to a trustee or other third person, the Contractor may consider as part of the wages of any laborer or mechanic the amount of any costs reasonably anticipated in providing bona fide fringe benefits under a

plan or program, provided that the Secretary of Labor has found, upon the written request of the Contractor, that the applicable standards of the Davis-Bacon Act have been met. The Secretary of Labor may require the Contractor to set aside in a separate account assets for the meeting of obligations under the plan or program.

B. Withholding

DCED or its designee shall upon its own action or upon written request of an authorized representative of the Department of Labor withhold or cause to be withheld from the Contractor under this contract or any other Federal contract with the same prime Contractor, or any other Federally-assisted contract subject to Davis-Bacon prevailing wage requirements, which is held by the same prime Contractor so much of the accrued payments or advances as may be considered necessary to pay laborers and mechanics, including apprentices, trainees and helpers, employed by the Contractor or any subcontractor the full amount of wages required by the contract. In the event of failure to pay any laborer or mechanic, including any apprentice, trainee or helper, employed or working on the site of the work, all or part of the wages required by the contract, DCED or its designee may, after written notice to the Contractor, sponsor, applicant, or owner, take such action as may be necessary to cause the suspension of any further payment, advance, or guarantee of funds until such violations have ceased. DCED or its designee may, after written notice to the Contractor, disburse such amounts withheld for and on account of the Contractor or subcontractor to the respective employees to whom they are due.

C. Payrolls and Basic Records

Payrolls and basic records relating thereto shall be maintained by the Contractor during the course of the work preserved for a period of three years thereafter for all laborers and mechanics working at the site of the work. Such records shall contain the name, address, and social security number of each such worker, his or her correct classification, hourly rates of wages paid (including rates of contributions or costs anticipated for bona fide fringe benefits or cash equivalents thereof of the types described in Section 1(b)(2)(B) of the Davis-Bacon Act), daily and weekly number of hours worked, deductions made and actual wages paid. Whenever the Secretary of Labor has found under 29 CFR 5.5 (a)(1)(iv) that the wages of any laborer or mechanic include the amount of any costs reasonably anticipated in providing benefits under a plan or program described in Section 1(b)(2)(B) of the Davis-Bacon Act, the Contractor shall maintain records which show that the commitment to provide such benefits is enforceable, that the plan or program is financially responsible, and that the plan or program has been communicated in writing to the laborers or mechanics affected, and records which show the costs anticipated or the actual cost incurred in providing such benefits. Contractors employing apprentices or trainees under approved programs shall maintain written evidence of the registration of apprenticeship programs and certification of trainee programs, the registration of the apprentices and trainees, and the ratios and wage rates prescribed in the applicable programs.

The Contractor shall submit weekly for each week in which any contract work is performed a copy of all payrolls to DCED or its designee if the agency is a party to the contract, but if the agency is not such a party, the Contractor will submit the payrolls to the applicant, sponsor, or owner, as the case may be, for transmission to DCED or its designee. The payrolls submitted shall set out accurately and completely all of the information required to be maintained under 29 CFR Part 5.5(a)(3)(i). This information may be submitted in any form desired. Optional Form WH-347 is available for this purpose and may be purchased from the Superintendent of Documents (Federal Stock Number 029-005-00014-1), U.S. Government Printing

Office, Washington, D.C. 20402. The prime Contractor is responsible for the submission of copies of payrolls by all subcontractors.

Each payroll submitted shall be accompanied by a "Statement of Compliance," signed by the Contractor or subcontractor or his or her agent who pays or supervises the payment of the persons employed under the contract and shall certify the following:

- (1) That the payroll for the payroll period contains the information required to be maintained under 29 CFR Part 5.5(a)(3)(i) and that such information is correct and complete;
- (2) That each laborer or mechanic (including each helper, apprentice, and trainee) employed on the contract during the payroll period has been paid the full weekly wages earned, without rebate, either directly or indirectly, and that no deductions have been made either directly or indirectly from the full wages earned, other than permissible deductions as set forth in 29 CFR Part 3;
- (3) That each laborer or mechanic has been paid not less than the applicable wage rates and fringe benefits or cash equivalents for the classification of work performed, as specified in the applicable wage determination incorporated into the contract.

The weekly submission of properly executed certification set forth on the reverse side of Optional Form WH-347 shall satisfy the requirement for submission of the "Statement of Compliance" required by paragraph A.3(ii)(b) of this section.

The falsification of any of the above certification may subject the Contractor or subcontractor to civil or criminal prosecution under Section 1001 of Title 18 and Section 231 of Title 31 of the United States Code.

The Contractor or subcontractor shall make the records required under paragraph A.3(i) of this section available for inspection, copying, or transcription by authorized representatives of DCED or its designee or the Department of Labor, and shall permit such representatives to interview employees during working hours on the job. If the Contractor or subcontractor fails to submit the required records or to make them available, DCED or its designee may, after written notice to the Contractor, sponsor, applicant, or owner, take such action as may be necessary to cause the suspension of any further payment, advance, or guarantee of funds. Furthermore, failure to submit the required records upon request or to make such records available may be grounds for debarment action pursuant to 29 CFR Part 5.12.

D. Apprentices and Trainees.

Apprentices. Apprentices will be permitted to work at less than the predetermined rate for the work they performed when they are employed pursuant to and individually registered in a bona fide apprenticeship program registered with the U.S. Department of Labor, Employment and Training Administration, Bureau of Apprenticeship and Training, or with a State Apprenticeship Agency recognized by the Bureau, or if a person is employed in his or her first 90 days of probationary employment as an apprentice in such an apprenticeship program, who is not individually registered in the program, but who has been certified by the Bureau of

Apprenticeship and Training or a State Apprenticeship Agency (where appropriate) to be eligible for probationary employment as an apprentice. The allowable ratio of apprentices to journeymen on the job site in any craft classification shall not be greater than the ratio permitted to the Contractor as to the entire work force under the registered program. Any worker listed on a payroll at an apprentice wage rate, who is not registered or otherwise employed as stated above, shall be paid not less than the applicable wage rate on the wage determination for the classification of work actually performed. In addition, any apprentice performing work on the job site in excess of the ratio permitted under the registered program shall be paid not less than the applicable wage rate on the wage determination for the work actually performed. Where a Contractor is performing construction on a project in a locality other than that in which its program is registered, the ratios and wage rates (expressed in percentages of the journeyman's hourly rate) specified in the Contractor's or subcontractor's registered program shall be observed. Every apprentice must be paid at not less than the rate specified in the registered program for the apprentice's level of progress, expressed as a percentage of the journeymen hourly rate specified in the applicable wage determination. Apprentices shall be paid fringe benefits in accordance with the provisions of the apprenticeship program. If the apprenticeship program does not specify fringe benefits, apprentices must be paid the full amount of fringe benefits listed on the wage determination for the applicable classification. If the administrator determines that a different practice prevails for the applicable apprentice classification, fringes shall be paid in accordance with that determination. In the event the Bureau of Apprenticeship and Training, or a State Apprenticeship Agency recognized by the Bureau, withdraws approval of an apprenticeship program, the Contractor will no longer be permitted to utilize apprentices at less than the applicable predetermined rate for the work performed until an acceptable program is approved.

Trainees. Except as provided in 29 CFR 5.16, trainees will not be permitted to work at less than the predetermined rate for the work performed unless they are employed pursuant to and individually registered in a program which has received prior approval, evidenced by formal certification by the U.S. Department of Labor, Employment and Training Administration. The ratio of trainees to journeymen on the job site shall not be greater than permitted under the plan approved by the Employment and Training Administration. Every trainee must be paid at not less than the rate specified in the approved program for the trainee's level of progress, expressed as a percentage of the journeyman hourly rate specified in the applicable wage determination. Trainees shall be paid fringe benefits in accordance with the provisions of the trainee program. If the trainee program does not mention fringe benefits, trainees shall be paid the full amount of fringe benefits listed on the wage determination unless the Administrator of the Wage and Hour Division determines that there is an apprenticeship program associated with the corresponding journeyman wage rate on the wage determination which provides for less than full fringe benefits for apprentices. Any employee listed on the payroll at a trainee rate who is not registered and participating in a training plan approved by the Employment and Training Administration shall be paid not less than the applicable wage rate on the wage determination for the work actually performed. In addition, any trainee performing work on the job site in excess of the ratio permitted under the registered program shall be paid not less than the applicable wage rate on the wage determination for the work actually performed. In the event the Employment and Training Administration withdraws approval of a training program, the Contractor will no longer be permitted to utilize trainees at less than the applicable predetermined rate for the work performed until an acceptable program is approved.

Equal employment opportunity. The utilization of apprentices, trainees and journeymen under this part shall be in conformity with the equal employment opportunity requirements of Executive Order 11246, as amended, and 29 CFR Part 30.

- E. **Compliance with Copeland Act requirements.** The Contractor shall comply with the requirements of 29 CFR Part 3 which are incorporated by reference in the contract.
- F. **Subcontracts.** The Contractor or subcontractor will insert in any subcontracts the clauses contained in 29 CFR 5.5(a)(1) through (10) and such other clauses as DCED or its designee may by appropriate instruction require, and also a clause requiring the subcontractors to include these clauses in any lower tier subcontracts. The prime contractor shall be responsible for the compliance by any subcontractor or lower tier subcontractor with all contract clauses in 29 CFR Part 5.5.
- G. **Contract termination; debarment.** A breach of the contract clauses in 29 CFR 5.5 may be grounds for termination of the contract, and for debarment as a contractor and a subcontractor as provided in 29 CFR 5.12.
- H. **Compliance with Davis-Bacon and Related Act Requirements.** All rulings and interpretations of the Davis-Bacon and Related Acts contained in 29 CFR Parts 1, 3, and 5 are herein incorporated by reference in this contract.
- I. **Disputes concerning labor standards.** Disputes arising out of the labor standards provisions of this contract shall not be subject to the general disputes clause of this contract. Such disputes shall be resolved in accordance with the procedures of the Department of Labor set forth in 29 CFR Parts 5, 6, and 7. Disputes within the meaning of this clause include disputes between the Contractor (or any of its subcontractors) and DCED or its designee, the U.S. Department of Labor, or the employees or their representatives.
- J. **Certification of Eligibility.**
 - (1) By entering into this contract, the Contractor certifies that neither it (nor he or she) nor any person or firm who has an interest in the Contractor's firm is a person or firm ineligible to be awarded Government contracts by virtue of Section 3(a) of the Davis-Bacon Act or 29 CFR 5.12(a)(1).
 - (2) No part of this contract shall be subcontracted to any person or firm ineligible for award of a Government contract by virtue of Section 3(a) of the Davis-Bacon Act or 29 CFR 5.12(a)(1).
 - (3) The penalty for making false statements is prescribed in the U.S. Criminal Code, 18 U.S.C. 1001. Additionally, U.S. Criminal Code, Section 1010, Title 18, U.S.C., "Federal Housing Administration transaction," provides in part: "Whoever, for the purpose of . . . influencing in any way the action of such Administration . . . makes, utters or publishes any statement, knowing the same to be false . . . shall be fined not more than \$5,000 or imprisoned not more than two years, or both."

- K. **Complaints, Proceedings, or Testimony by Employees.** No laborer or mechanic to whom the wage, salary, or other labor standards provisions of this contract are applicable shall be discharged or in any other manner discriminated against by the Contractor or any subcontractor because such employee has filed any complaint or instituted or caused to be instituted any proceeding or has testified or is about to testify in any proceeding under or relating to the labor standards applicable under this Contract to his employer.
3. **Contract Work Hours and Safety Standards Act.** As used in this paragraph, the terms “laborers” and “mechanics” include watchmen and guards.
- A. **Overtime requirements.** No Contractor or subcontractor contracting for any part of the contract work which may require or involve the employment of laborers or mechanics shall require or permit any such laborer or mechanic in any work week in which he or she is employed on such work to work in excess of forty hours in such work week unless such laborer or mechanic received compensation at a rate not less than one and one-half times the basic rate of pay for all hours worked in excess of forty hours in such work week.
- B. **Violation; liability for unpaid wages; liquidated damages.** In the event of any violation of the clause set forth in subparagraph (A) “**Overtime requirements,**” the Contractor and any subcontractor responsible therefor shall be liable for the unpaid wages. In addition, such Contractor and subcontractor shall be liable to the United States (in the case of work done under contract for the District of Columbia or a territory, to such District or to such territory), for liquidated damages. Such liquidated damages shall be computed with respect to each individual laborer or mechanic, including watchmen and guards, employed in violation of the clause set forth in subparagraph (A) “**Overtime requirements,**” in the sum of \$10 for each calendar day on which such individual was required or permitted to work in excess of the standard work week of forty hours without payment of the overtime wages required by the clause set forth in subparagraph (A) “**Overtime requirements.**”
- C. **Withholding for unpaid wages and liquidated damages.** DCED or its designee shall upon its own action or upon written request of an authorized representative of the Department of Labor withhold or cause to be withheld, from any moneys payable on account of work performed by the Contractor or subcontractor under any such contract or any other Federal contract with the same prime contract, or any other Federally assisted contract subject to the Contract Work Hours and Safety Standards Act, which is held by the same prime Contractor such sums as may be determined to be necessary to satisfy any liabilities of such Contractor or subcontractor for unpaid wages and liquidated damages as provided in the clause set forth in subparagraph (B) “**Violation; liability for unpaid wages; liquidated damages.**”
- D. **Subcontracts.** The Contractor or subcontractor shall insert in any subcontracts the clauses set forth in subparagraph (A) through (D) of Section 3 “**Contract Work Hours and Safety Standards Act**” and also a clause requiring the subcontractors to include these clauses in any lower tier subcontracts. The prime Contractor shall be responsible for compliance by any subcontractor or lower tier subcontractor with the clauses set forth in subparagraphs (A) through (D) of Section 3 “**Contract Work Hours and Safety Standards Act.**”
4. **Health and Safety**

- A. No laborer or mechanic shall be required to work in surroundings or under working conditions which are unsanitary, hazardous, or dangerous to his health and safety as determined under construction safety and health standards promulgated by the Secretary of Labor by regulation.

- B. The Contractor shall comply with all regulations issued by the Secretary of Labor pursuant to Title 29 Part 1926 (formerly part 1518) and failure to comply may result in imposition of sanctions pursuant to the Contract Work Hours and Safety Standards Act (Public Law 91-54, 83 Stat. 96).
- C. The Contractor shall include the provisions of this Article in every subcontract so that such provisions will be binding on each subcontractor. The Contractor shall take such action with respect to any subcontract as the Secretary of the Department of Community and Economic Development or the Secretary of Labor shall direct as a means of enforcing such provisions.

VI. SECTION 3 OF THE HOUSING AND URBAN DEVELOPMENT ACT OF 1968 (12 U.S.C. 1701 u).

- 1. This Agreement is subject to the requirements of Section 3 of the Housing and Urban Development Act of 1968 (12 U.S.C. 1701 u) as amended, the regulations issued at 24 CFR Part 135, and any applicable rules and orders of DCED issued thereunder prior to the execution of this Agreement. The Section 3 clause set forth in 24 CFR Part 135.20(b) provides: Every applicant, recipient, contracting party, Contractor, and subcontractor shall incorporate, or cause to be incorporated in all contracts for work in connection with a Section 3 covered project, the following clause (referred to as a Section 3 clause):
 - A. The work to be performed under this contract is on a project assisted under the State's Small Communities Program which provides Federal financial assistance from the Department of Housing and Urban Development and is subject to the requirements of Section 3 of the Housing and Urban Development Act of 1968, as amended, 12 U.S.C. 1701 u. Section 3 requires that to the greatest extent feasible opportunities from training and employment be given lower income residents of the project area and contracts for work in connection with the project to be awarded to business concerns which are located in, or owned in substantial part by persons residing in the area of the project.
 - B. The parties to the contract will comply with the provisions of said Section 3. The parties to the contract certify and agree that they are under no contractual or other disability which would prevent them from complying with these requirements.
 - C. The Contractor will send to each labor organization or representative of workers with which he has a collective bargaining agreement or other contract or understanding, if any, a notice advising the said labor organization or workers' representative of his commitments under this Section 3 clause and shall post copies of the notice in conspicuous places available to employees and applicants for employment training.
 - D. The Contractor will include this Section 3 clause in every subcontract for work in connection with the project and will, at the direction of the applicant for or recipient of Federal financial assistance, take appropriate action pursuant to the subcontract upon a finding that the subcontractor is in violation of these regulations. The Contractor will not subcontract with any subcontractor where it has notice or knowledge that the latter has been found in violation of these regulations under 24 CFR Part 135 and will not let any subcontract unless the subcontractor has first provided it with a preliminary statement of ability to comply with the requirements of these regulations.

- E. Compliance with the provisions of Section 3 and the regulations set forth in 24 CFR Part 135, shall be a condition of the Federal financial assistance provided to the project, binding upon the applicant or recipient for such assistance, its successors and assigns. Failure to fulfill these requirements shall subject the applicant or recipient, its contractors and subcontractors, its successors and assigns to those sanctions specified by the grant or loan agreement or contract through which Federal assistance is provided, and to such sanctions as are specified by 24 CFR Part 135.
2. The Contractor agrees to abide by the Section 3 clause set for above and will also cause this Section clause to be inserted in any subcontracts entered into with third parties for work covered by this agreement.
3. Prior to the signing of the Contract, the Contractor shall prepare and submit to the Local Public Agency a preliminary statement of work-force needs and identify targets for employment of trainees and regular work force, and for business utilization. Each subcontractor shall be required by the Contractor to prepare and submit to the same documents as are required of the Contractor. Forms of statement and target identification, and the Contractor's Certification of Compliance meeting the requirements of this Section are attached hereto and incorporated herein by reference.

VII. LEAD BASED PAINT REQUIREMENTS.

Title IV of the Lead-Based Paint Poisoning Prevention Act (42 U.S.C. 4831) prohibits the use of lead-based paint in residential structures constructed or rehabilitated with Federal assistance in any form.

VIII. CLEAN AIR AND CLEAN WATER ACTS.

This Agreement is subject to the requirements of the Clean Air Act, as amended, 42 U.S.C. 1857 et. seq., and the regulations of the Environmental Protection Agency with respect thereto, at 40 CFR Part 15, as amended from time to time.

The Contractor and any of its subcontractors for work funded under the Agreement which is excess of \$100,000 agree to the following requirements:

- (1) A stipulation by the Contractor or subcontractors that any facility to be utilized in the performance of any non-exempt contract or subcontract is not listed on the List of Violating Facilities issued by the Environmental Protection Agency (EPA) pursuant to 40 CFR 15.20.
- (2) Agreement by the Contractor to comply with all the requirements of Section 114 of the Clean Air Act, as amended (42 U.S.C. 1857c-8) and Section 308 of the Federal Water Pollution Control Act, as amended. (33 U.S.C. 1318) relating to the inspection, monitoring, entry, reports and information, as well as all other requirements specified in said Section 114 and Section 308, and all regulations, and guidelines issued thereunder.
- (3) A stipulation that as a condition for the award of the contract prompt notice will be given of any notification received from the Director, Office of Federal Activities, EPA, indicating that a facility utilized or to be utilized for the contract is under consideration to be listed on the EPA List of Violating Facilities.
- (4) Agreement by the Contractor that he will include or cause to be included the criteria and requirements in paragraph (1) through (4) of this section in every nonexempt subcontract and

requiring that the Contractor will take such action as the Government may direct as a means of enforcing such provision.

IX. ENERGY CONSERVATION PROVISIONS.

Contractors must recognize mandatory standards and policies relating to energy efficiency contained in the Cost Effective Energy Conservation Measures.

X. SECTION 109 OF THE HOUSING AND COMMUNITY DEVELOPMENT ACT OF 1974.

“No person in the United States shall on the grounds of race, color, national origin, or sex be excluded from participation in, be denied the benefits of, or be subjected to discrimination under any program or activity funded in whole or in part with funds made available under this Title.”

XI. EXECUTIVE ORDER 11625 - MINORITY BUSINESS ENTERPRISE, AND EXECUTIVE ORDER 12138 -- WOMEN’S BUSINESS ENTERPRISE.

- A. It is the policy of the Local Public Agency to take positive steps to maximize the utilization of minority business enterprises and women’s business enterprises in all contract activity administered by the Local Public Agency.
- B. The Contractor will use his best efforts to carry out this policy in the award of his subcontracts and in obtaining materials and supplies to the fullest extent consistent with the efficient performance of this contract.
- C. Commitments to MBE and WBE firms made at the time of bidding must be maintained throughout the term of the contract, unless a change in commitment to these firms is preapproved by the Local Public Agency or the administering agency performing the evaluation of the bid.
- D. The prime Contractor must provide the Local Public Agency with a report of MBE/WBE subcontracting activity on a quarterly or a per project basis, whichever is sooner. The report shall reflect the names of and the total dollar amount paid to all MBE/WBE subcontractors (including suppliers) utilized under this contract.
- E. MBE/WBE subcontractors and suppliers must provide the Local Public Agency with a report reflecting the prime contractors who have purchased their services and/or supplies on a quarterly or per project basis. The report shall reflect the name of the prime contractor and the total dollar amount invoiced and total dollar amount received for payment.
- F. The Local Public Agency may obtain documents and information from any bidder, contractor, subcontractor supplier or manufacturer that may be required in order to ascertain bidder or contractor responsibility. Failure to provide requested information may result in the contractor being declared not responsible.

XII. AGE DISCRIMINATION ACT OF 1975.

No person in the United States shall, on the basis of age, be excluded from participation in, be denied the benefits of, or be subjected to discrimination under, any program or activity receiving Federal financial assistance.

XIII. SECTION 504 HANDICAPPED (IF \$2,500 OR OVER).

Affirmative Action for Handicapped Workers

- A. The Contractor will not discriminate against any employee or applicant for employment because of physical or mental handicap in regard to any position for which the employee or applicant for employment is qualified. The Contractor agrees to take affirmative action to employ, advance in employment and otherwise treat qualified handicapped individuals without discrimination based upon their physical or mental handicap in all employment practices such as the following: Employment upgrading, demotion or transfer, recruitment, advertising, layoff or termination, rates of pay or other forms of compensation, and selection for training, including apprenticeship.
- B. The Contractor agrees to comply with the rules, regulations, and relevant orders of the Secretary of Labor issued pursuant to the Act.
- C. In the event of the Contractor's noncompliance with the requirements of this clause, actions for noncompliance may be taken in accordance with the rules, regulations, and relevant orders of the Secretary of Labor issued pursuant to the Act.
- D. The Contractor agrees to post in conspicuous places, available to employees and applicants for employment, notices in a form to be prescribed by the Director, provided by or through the contracting officer. Such notices shall state the Contractor's obligation under the law to take affirmative action to employ and advance in employment qualified handicapped employees and applicants for employment, and the rights of applicants and employees.
- E. The Contractor will notify each labor union or representative or workers with which it has a collective bargaining agreement or other contract understanding, that the Contractor is bound by the terms of Section 503 of the Rehabilitation Act of 1973, and is committed to take affirmative action to employ and advance in employment physically and mentally handicapped individuals.
- F. The Contractor will include the provisions of this clause in every subcontract or purchase order of \$2,500 or more unless exempted by rules, regulations, or orders of the Secretary issued pursuant to Section 503 of the Act, so that such provisions will be binding upon each subcontractor or vendor. The Contractor will take such action with respect to any subcontract or purchase order as the Director of the Office of Federal Contract Compliance Programs may direct to enforce such provisions, including action for non-compliance.

STATE REQUIREMENTS

All Bidders must also comply with the following State requirements:

XIV. PENNSYLVANIA STEEL PRODUCTS PROCUREMENT ACT (NO. 178-3).

If any steel products are to be used or supplied in the performance of the Contract, only steel products produced in the United States shall be used or supplied in the performance of the Contract or any subcontracts thereunder. This provision shall not apply in any case where the head of the public agency, in writing, determines that the type of steel products necessary to the performance of the Contract are not produced in the United States in sufficient quantities to meet the requirements of the Contract.

XV. PENNSYLVANIA HUMAN RELATIONS ACT, AS AMENDED.

NONDISCRIMINATION CLAUSE

During the term of this contract, Contractor agrees as follows:

1. Contractor shall not discriminate against any employee, applicant for employment independent contractor, or any other person because of race, color, religious creed, ancestry, national origin, age, or sex.

Contractor shall take affirmative action to ensure that applicants are employed, and that employees or agents are treated during employment, without regard to their race, color, religious creed, handicaps, ancestry, national origin, age, or sex. Such affirmative action shall include, but is not limited to: employment, upgrading, demotion or transfer, recruitment or recruitment advertising; layoff or termination; rates of pay or other forms of compensation; and selection for training.

Contractor shall post in conspicuous places available to employees, agents, applicants for employment, and other persons, a notice to be provided by the contracting agency setting forth the provisions of this nondiscrimination clause.

2. Contractor shall, in advertisements of requests for employment placed by it or on its behalf, state that all qualified applicants will receive consideration for employment without regard to race, color, religious creed, handicap, ancestry, national origin, age, or sex.
3. Contractor shall send each labor union or workers' representative with which it has a collective bargaining agreement or other contract or understanding, a notice advising said labor union or workers' representative of its commitment to this nondiscrimination clause. Similar notice shall be sent to every other source of recruitment regularly utilized by Contractor.
4. It shall be no defense to a finding of noncompliance with this nondiscrimination clause that Contractor has delegated some of its employment practices to any union, training program, or other source of recruitment that prevents it from meeting its obligations. However, if the evidence indicates that the Contractor was not on notice of the third-party discrimination or made a good faith effort to correct it, such factor shall be considered in mitigation in determining appropriate sanctions.

5. Where the practices of a union or any training program or other source of recruitment will result in the exclusion of minority group persons, so that Contractor will be unable to meet its obligations under this nondiscrimination clause, Contractor shall then employ and fill vacancies through other nondiscriminatory employment procedures.
6. Contractor shall comply with all state and federal laws prohibiting discrimination in hiring or employment opportunities. In the event of Contractor's noncompliance with the nondiscrimination clause of this contract or with any such laws, this contract may be terminated or suspended, in whole or in part, and Contractor may be declared temporarily ineligible for further Commonwealth contracts, and other sanctions may be imposed and remedies invoked.
7. Contractor shall furnish all necessary employment documents and records to, and permit access to its books, records, and accounts by the contracting agency for purposes of investigation to ascertain compliance with the provisions of this clause. If Contractor does not possess documents or records reflecting the necessary information requested, it shall furnish such information on reporting forms supplied by the contracting agency.
8. Contractor shall actively recruit minority and women subcontractors or subcontractors with substantial minority representation among their employees.
9. Contractor shall include the provisions of this nondiscrimination clause in every subcontract, so that such provisions will be binding upon each Subcontractor.
10. Contractor obligations under this clause are limited to the Contractor's facilities within Pennsylvania or, where the contract is for purchase of goods manufactured outside of Pennsylvania, the facilities at which such goods are actually produced.

XVI. *Pennsylvania Act 187 of 1966 – Call before you dig!*

1. It is the responsibility of the Contractor to comply with the Pennsylvania Underground Utility Line Protection Law. PA Act 187 of 1966 and Act 287 of 1974 as amended by Act 199 of 2004 and any other subsequent amendments.
2. The Contractor shall be responsible for notifying all utility companies at least seventy two (72) Hours before any work is commenced.
3. Exact location, depth and size of all existing utilities in the project area shall be verified in the field by the Contractor with a representative from the appropriate utility company.
4. Pennsylvania One Call, 1-800-242-1776, **Call before you dig!**

NONDISCRIMINATION/SEXUAL HARASSMENT CLAUSE

During the term of this contract, the contractor agrees as follows:

1. In the hiring of any employee(s) for the manufacture of supplies, performance of work, or any other activity required under the contract or any subcontract, the contractor, subcontractor, or any person acting on behalf of the contractor or subcontractor shall not, by reason of gender, race, creed, or color, discriminate against any citizen of this Commonwealth who is qualified and available to perform the work to which the employment relates.
2. Neither the contractor nor any subcontractor nor any person on their behalf shall in any manner discriminate against or intimidate any employee involved in the manufacture of supplies, the performance of work, or any other activity required under the contract on account of gender, race, creed, or color.
3. Contractors and subcontractors shall establish and maintain a written sexual harassment policy and shall inform their employees of the policy. The policy must contain a notice that sexual harassment will not be tolerated and employees who practice it will be disciplined.
4. Contractors shall not discriminate by reason of gender, race, creed, or color against any subcontractor or supplier who is qualified to perform the work to which the contracts relates.
5. The contractor and each subcontractor shall furnish all necessary employment documents and records to and permit access to their books, records, and accounts by the contracting agency and the Bureau of Contract Administration and Business Development, for purposes of investigation, to ascertain compliance with provisions of this Nondiscrimination/Sexual Harassment Clause. If the contractor or any subcontractor does not possess documents or records reflecting the necessary information requested, the contractor or subcontractor shall furnish such information on reporting forms supplied by the contracting agency or the Bureau of Contract Administration and Business Development.
6. The contractor shall include the provisions of this Nondiscrimination/Sexual Harassment Clause in every subcontract so that such provisions will be binding upon each subcontractor.
7. The Commonwealth may cancel or terminate the contract and all money due or to become due under the contract may be forfeited for a violation of the terms and conditions of this Nondiscrimination/Sexual Harassment Clause. In addition, the agency may proceed with debarment or suspension and may place the contractor in the Contractor Responsibility File.

THIS PAGE INTENTIONALLY LEFT BLANK

GENERAL SPECIFICATIONS

SPECIAL CONDITIONS FOR SITE PREPARATION PART III

301. PROJECT SITE

The Project Area of this Site Preparation Contract consists of the following general area: **East Blackberry Street, Jonestown Borough, Lebanon County, Pennsylvania**, all as shown on the Construction Drawings designated as **Sheets No. 1-4**.

302. TIME FOR COMPLETION

a. The work which the Contractor is required to perform under this Contract shall be commenced at the time stipulated by the Local Public Agency in the Notice to Proceed to the Contractor and shall be fully completed **by October 15, 2022**, with the exception of the **work on the curb ramps which must be completed by August 19, 2022** to avoid conflicts with school traffic and pedestrian flows.

303. LIQUIDATED DAMAGES

As actual damages for any delay in completion of the work which the Contractor is required to perform under this contract are impossible for determination, the Contractor and his Sureties shall be liable for and shall pay to the Local Public Agency the sum of **\$200.00** as fixed, agreed and liquidated damages for each calendar day of delay from the above stipulated for completion, or as modified in accordance with Section 109 - CHANGES IN THE WORK under GENERAL CONDITIONS - PART I, until such work is satisfactorily completed and accepted.

304. RESPONSIBILITIES OF CONTRACTOR

Except as otherwise specifically stated in the Contract Documents and Technical Specifications, the Contractor shall provide and pay for all materials, labor, tools, equipment, water, light, heat, power, transportation, superintendence, temporary construction of every nature, charges, levies, fee or other expenses and all other services and facilities of every nature whatsoever necessary for the performance of the Contract and to deliver all improvements embraced in this Contract for Site Preparation complete in every respect within the specified time.

305. COMMUNICATIONS

- a. All Notices, demands, requests, instructions, approvals, proposals and claims must be in writing.
- b. Any notice to or demand upon the Contractor shall be sufficiently given if delivered at the office of the Contractor stated on the signature page of the Agreement (or at such other office as the Contractor may from time to time designate in writing to the Local Public Agency), or if deposited in the United States mail in a sealed, postage prepaid envelope, or delivered with charges prepaid to any telegraph company for transmission, in each case addressed to such office.

c. All papers required to be delivered to the Local Public Agency shall, unless otherwise specified in writing to the Contractor, be delivered, or if deposited in the United States mail in a sealed, postage prepaid envelope, or delivered with charges prepaid to any telegraph company for transmission to said Local Public Agency at such address, or to such other representatives of the Local Public Agency or to such other address as the Local Public Agency may subsequently specify in writing to the Contractor for such purpose.

d. Any such notice shall be deemed to have been given as of the time of actual delivery or (in the case of mailing) when the same should have been received in due course of post, or in the case of telegrams, at the time of actual receipt, as the case may be.

306. SIGNS

- a. The Contractor shall erect two (2) signs, provided by the Owner, containing the following information: Short name of site preparation activity, identification of the Local Public Agency and the legislative act under which funds are provided. Signs shall meet the specifications of the Local Government and be placed at the direction of the Engineer or Owner.
- b. The Contractor shall maintain these Project Signs in good condition satisfactory to the Local Public Agency during the period of his performance of this Contract and upon completion of the Contract work, or when directed, shall turn them over to the Local Public Agency in place cleaned, (freshly painted and lettered, if required), and in acceptable condition.
- c. Subject to prior approval of the Local Public Agency as to size, design, type and location and to local regulations, the Contractor and his subcontractors may erect temporary signs for purposes of identification and controlling traffic. The Contractor shall furnish, erect and maintain such other signs as may be required by Safety Regulations or as necessary to safeguard life and property.

307. JOB OFFICES

- a. The Contractor and his subcontractors may maintain such office and storage facilities on the Site as are necessary for the proper conduct of the work. These shall be located so as to cause no interference to any work to be performed on the Site. The Local Public Agency shall be consulted with regard to locations.
- b. If no office is maintained, a suitable place for posting required notices, with adequate protection from the weather, shall be provided.
- c. Upon completion of the Improvements, or as directed by the Local Public Agency the Contractor shall remove all such temporary structures and facilities from the Site, same to become his property, and leave the Site of the work in the condition required by the Contract.

308. PARTIAL USE OF SITE IMPROVEMENTS

The Local Public Agency, at its election, may give notice to the Contractor and place in use those sections of the Improvements which have been completed, inspected and can be accepted as

complying with the Technical Specifications, and if in its opinion each such section is reasonably safe, fit and convenient for the use and accommodation for which it was intended, provided:

- a. The use of such sections of the Improvements shall in no way impede the completion of the remainder of the work by the Contractor.
- b. The Contractor shall not be responsible for any damages or maintenance costs due directly to the use of such sections.
- c. The use of such sections shall in no way relieve the Contractor of his liability due to having used defective materials or to poor workmanship.
- d. The period of guarantee stipulated in the Section 132 - GENERAL GUARANTY under GENERAL CONDITIONS, PART I, shall not begin to run until the date of the final acceptance of all work which the Contractor is required to construct under this Contract.

309. WORK BY OTHERS

None

310. CONTRACT DOCUMENTS AND DRAWINGS

The Local Public Agency will furnish the Contractor without charge three (3) copies of the Contract Documents, including Technical Specifications and Drawings. Additional copies requested by the Contractor will be furnished at cost.

311. OTHER SPECIAL CONDITIONS

THIS PAGE INTENTIONALLY LEFT BLANK

CONTRACT CHANGE ORDER

REDEVELOPMENT AUTHORITY OF THE COUNTY OF LEBANON, PENNSYLVANIA

Contract No. _____ Project Name _____

Change Order No. _____ Date _____

To: (Contractor) _____

You are hereby requested to comply with the following changes from the Contract Plans and Specifications:

Item No.	Description of Changes - Quantities, Units Completion Schedule, Etc.	Decrease in Contract Price	Increase in Contract Price
	Change in contract price due to this Change Order:		
	Total Decrease	\$ _____	
	Total Increase		\$ _____
	Difference	\$ _____	\$ _____
	Net (increase) (decrease)	\$ _____	\$ _____

The sum of \$ _____ is hereby added to (deducted from) the total Contract price.

The time provided for completion in the Contract is unchanged (increased, decreased by _____ calendar days). This document shall become an amendment to the Contract and all provisions of the Contract will apply hereto.

Accepted by: _____ (Contractor) _____ (Date)

Recommended by: _____ (Engineer) _____ (Date)

Approved by: _____ (Owner) _____ (Date)

THIS PAGE INTENTIONALLY LEFT BLANK

CHANGE ORDER - TIME ONLY INVOLVED

REDEVELOPMENT AUTHORITY OF THE COUNTY OF LEBANON, PA

_____	_____
(Name of Contractor)	(Date)
_____	_____
(Number and Street)	(Name of Project)
_____	_____
(City)	(State and Zip Code)

CHANGE ORDER NO. _____

Gentlemen:

In connection with Contract No. _____, dated _____, for

located in _____, Pennsylvania.

1. The completion of the work has been delayed by reason of: _____
_____ and _____

2. The Local Public Agency has duly determined that:

- (a) The delay was due to unforeseeable causes beyond your control and without your fault or negligence;
- (b) Notice of the cause of the delay was given within the time and in the manner prescribed by the contract; and
- (c) The causes of delay justify and require an extension of the time as herein provided as a matter of legal right without the assertion of a claim by the owner for (actual) (liquidated) damages because of the contractor's failure to complete the work within the number of days specified by the contract.

Subject to conditions hereinafter set forth, an equitable adjustment of the contract time is established, as follows:

THE CONTRACT TIME IS EXTENDED (_____) CALENDAR DAYS

The conditions last above referred to are as follows:

- A. The aforementioned adjustment of contract time is subject to all contract stipulations and covenants;
- B. The rights of the Local Public Agency are not prejudiced; and
- C. All claims against the Local Public Agency which are incidental to or as a consequence of the aforementioned delay are satisfied.

Accepted _____
(Contractor)

REDEVELOPMENT AUTHORITY OF THE
COUNTY OF LEBANON, PENNSYLVANIA

By _____

By _____

Title _____

Title _____

Date _____

Date _____

CONTRACTOR'S CERTIFICATE AND RELEASE

From: _____
(Name of Contractor)

To: REDEVELOPMENT AUTHORITY OF THE COUNTY OF LEBANON

Reference Contract No. _____ entered into the _____ day of _____
20____, between the REDEVELOPMENT AUTHORITY OF THE COUNTY OF LEBANON, and

(Name of Contractor)

of _____
(City) (State)

for the _____
(Name of Operations)

part of the _____
(Name of Project)

located in _____, PENNSYLVANIA.

KNOW ALL MEN BY THESE PRESENTS:

1. The undersigned hereby certifies that there is due from and payable by the Local Public Agency to the Contractor under the contract and duly approved Change Orders and Modifications the balance of \$_____.

2. The undersigned further certifies that in addition to the amount set forth in paragraph 1, there are outstanding and unsettled the following items which he claims are just and due and owing by the Redevelopment Authority of the County of Lebanon to the Contractor:

3. The undersigned further certifies that all work required under this contract including work required under Change Orders numbered _____ has been performed in accordance with the terms thereof, and that there are no unpaid claims for materials, supplies or equipment and no claims of laborers or mechanics for unpaid wages arising out of the performance of this contract, and that the wage rates paid by the Contractor and all subContractors were in conformity with the contract provisions relating to said wage rates.

4. Except for the amounts stated under paragraphs 1 and 2 hereof, the undersigned has received from the Redevelopment Authority of the County of Lebanon all sums of money payable to the undersigned under or pursuant to the above mentioned contract or any modification or change thereof.

5. That in consideration of the payment of the amount stated in paragraph 1 hereof the undersigned does hereby release the Redevelopment Authority of the County of Lebanon from any and all claims arising under or by virtue of this contract, except the amount listed in paragraph 2 hereof; provided, however, that if for any reason the Redevelopment Authority of the County of Lebanon does not pay in full the amount stated in paragraph 1 hereof, said deduction shall not affect the validity of this release, but the amount so deducted shall be automatically included under paragraph 2 as an amount which the Contractor has not released but will release upon payment thereof. The Contractor further certifies that upon the payment of the amount listed in paragraph 2 hereof, and of any amount which may be deducted from paragraph 1 hereof, he will release the Redevelopment Authority of the County of Lebanon from any and all claims of any nature whatsoever arising out of said contract or modification thereof, and will execute such further releases or assurances as the Redevelopment Authority of the County of Lebanon may request.

IN WITNESS WHEREOF, the undersigned has signed and sealed this instrument this _____ day of _____, 20____.

_____(SEAL)

(Signature and Title of Officer)

_____, being first duly sworn on oath, deposes and says,
(Affiant)

first, that he is the

_____ of the _____
(Title) (Name of Company)

second, that he has read the foregoing certificate by him subscribed as

_____ of the _____
(Title) (Name of Company)

Affiant further states that the matters and things stated therein are, to the best of his knowledge and belief, true.

(Affiant)

Subscribed and sworn to before me this _____ day of _____ 20____.

My commission expires _____.

(Notary)

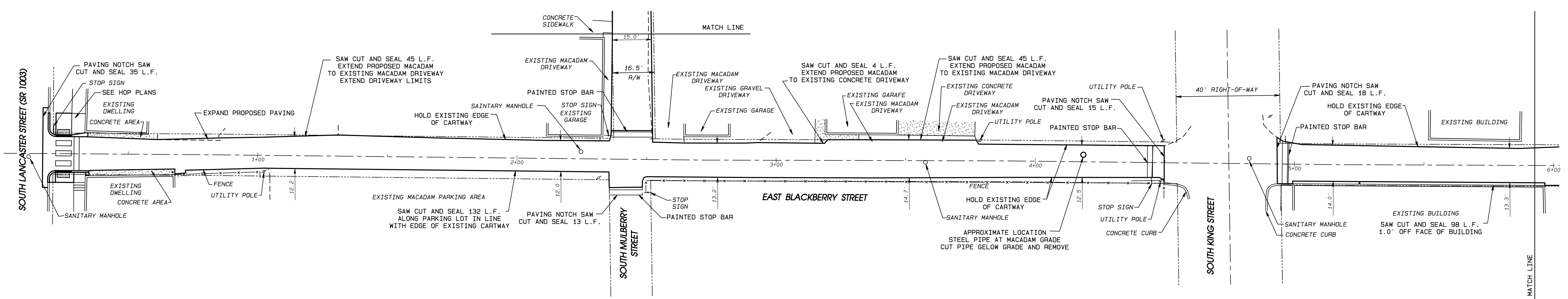

IMPROVEMENT PLAN
HORIZONTAL SCALE 1" = 20'

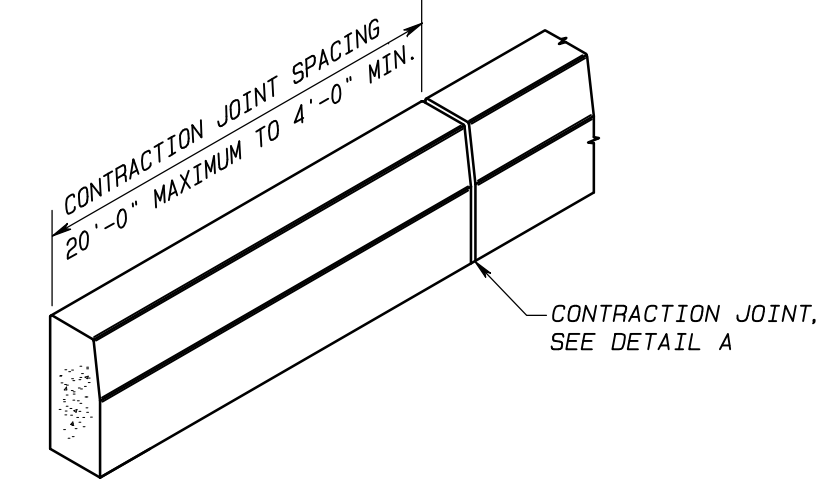
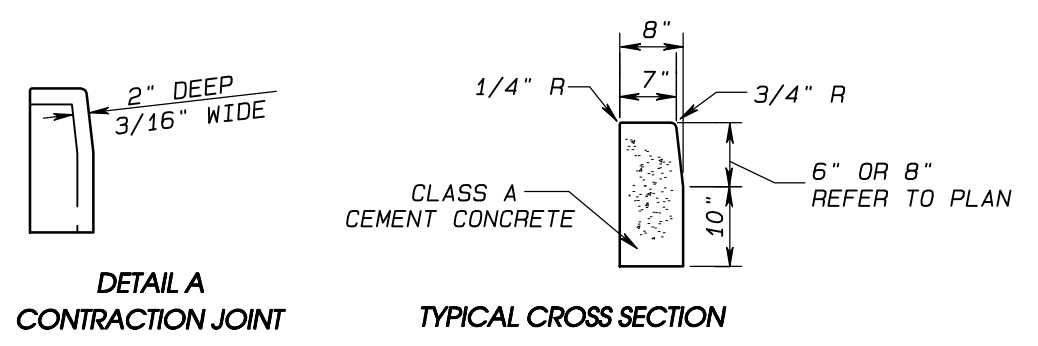
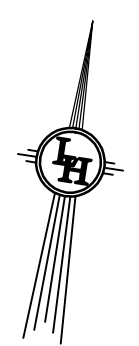

- NOTES**
- MATERIALS AND CONSTRUCTION SHALL MEET THE REQUIREMENTS OF PUBLICATION 408, SECTION 630 FOR PLAIN CEMENT CONCRETE CURB.
 - SPACE CONTRACTION JOINTS IN UNIFORM LENGTHS OR SECTIONS.
 - PLACE 3/4" PREMOULDED EXPANSION JOINT FILLER MATERIAL AT STRUCTURES AND AT THE END OF THE WORK DAY. CUT MATERIAL TO CONFORM TO AREA ADJACENT TO CURB OR TO CONFORM TO CROSS SECTIONAL AREA OF CURB.

PLAIN CEMENT CONCRETE CURB
NOT TO SCALE

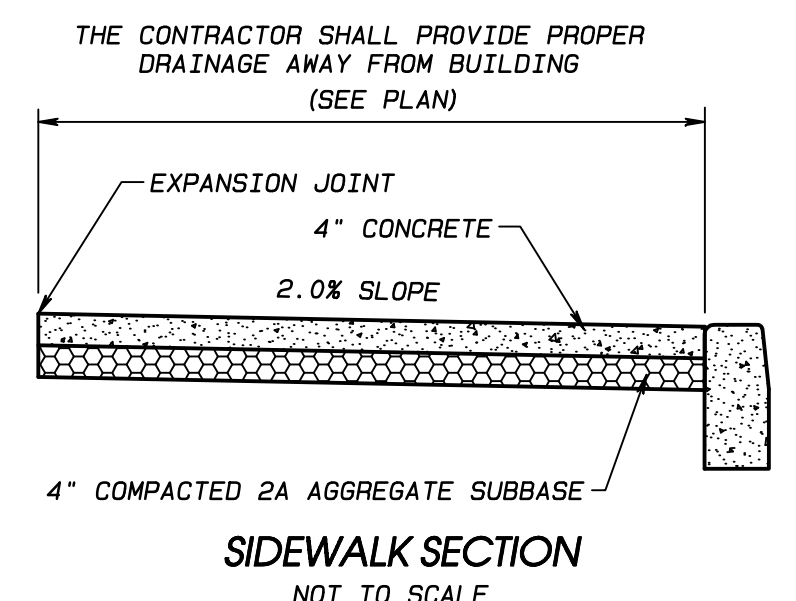

SIDEWALK SHALL BE CONSTRUCTED PER PENNDOT PUB. 408 SECTION 676 AND PUB. 72M.

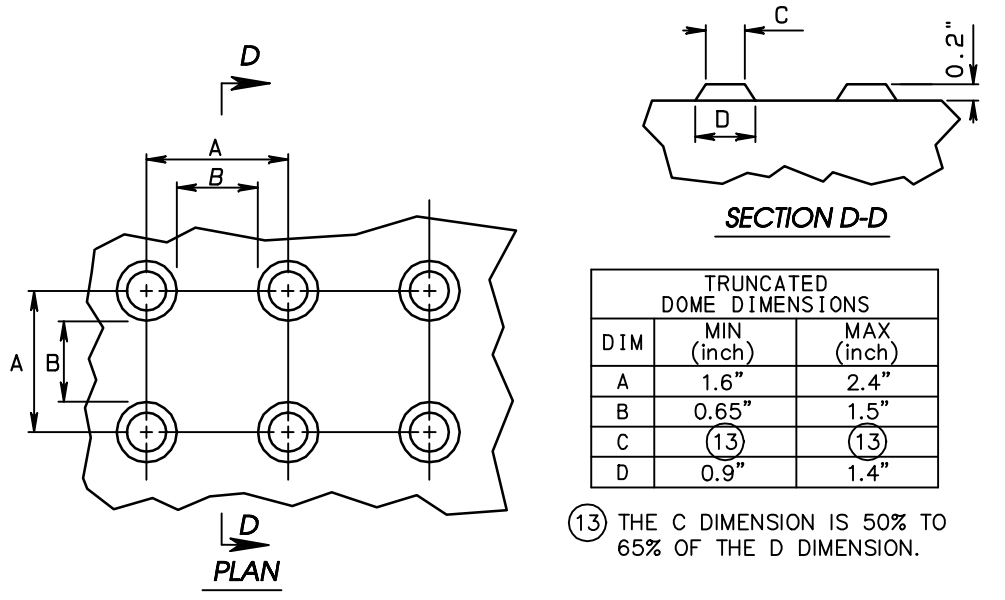

PENNDOT DETECTABLE WARNING SURFACE (DWS) TRUNCATED DOME DETAILS
NOT TO SCALE

TRUNCATED DOME DIMENSIONS		
DIM	MIN (inch)	MAX (inch)
A	1.6"	2.4"
B	0.65"	1.5"
C	(3)	(3)
D	0.9"	1.4"

(13) THE C DIMENSION IS 50% TO 65% OF THE D DIMENSION.

- NOTES:**
- CURB RAMPS REQUIRE A 5' MINIMUM LANDING WITH A MAXIMUM CROSS SLOPE AND LONGITUDINAL SLOPE OF 2.0% WHERE PEDESTRIAN PERFORM TURNING MANEUVERS. SEE PLAN VIEW FOR ADDITIONAL INFORMATION.
 - SIDE FLARES OF CURB RAMPS = 10.00%
 - RAMP SLOPES = 8.33%
 - THE CONTRACTOR IS RESPONSIBLE TO INSTALL THE CURB CUT RAMPS TO THE LATEST ADA OR PENNDOT STANDARDS AT THE TIME OF CONSTRUCTION.
 - SHOP DRAWINGS SHOWING SPOT ELEVATIONS OF THE PROPOSED CURB RAMPS SHALL BE PROVIDED TO THE MUNICIPAL ENGINEER TO CONFIRM COMPLIANCE WITH THE LATEST ADA REQUIREMENTS.
 - THE DETECTABLE WARNING SURFACE FOR CURB CUT RAMPS SHALL BE ARMORCAST REPLACEABLE DETECTABLE WARNING PANELS AS MANUFACTURED BY ARMORCAST PRODUCTS COMPANY. THE PANELS SHALL BE PROVIDED AND INSTALLED ACCORDING TO THE MANUFACTURER'S SPECIFICATIONS AND SHALL MEET ALL APPLICABLE PENNDOT AND ADA REQUIREMENTS.

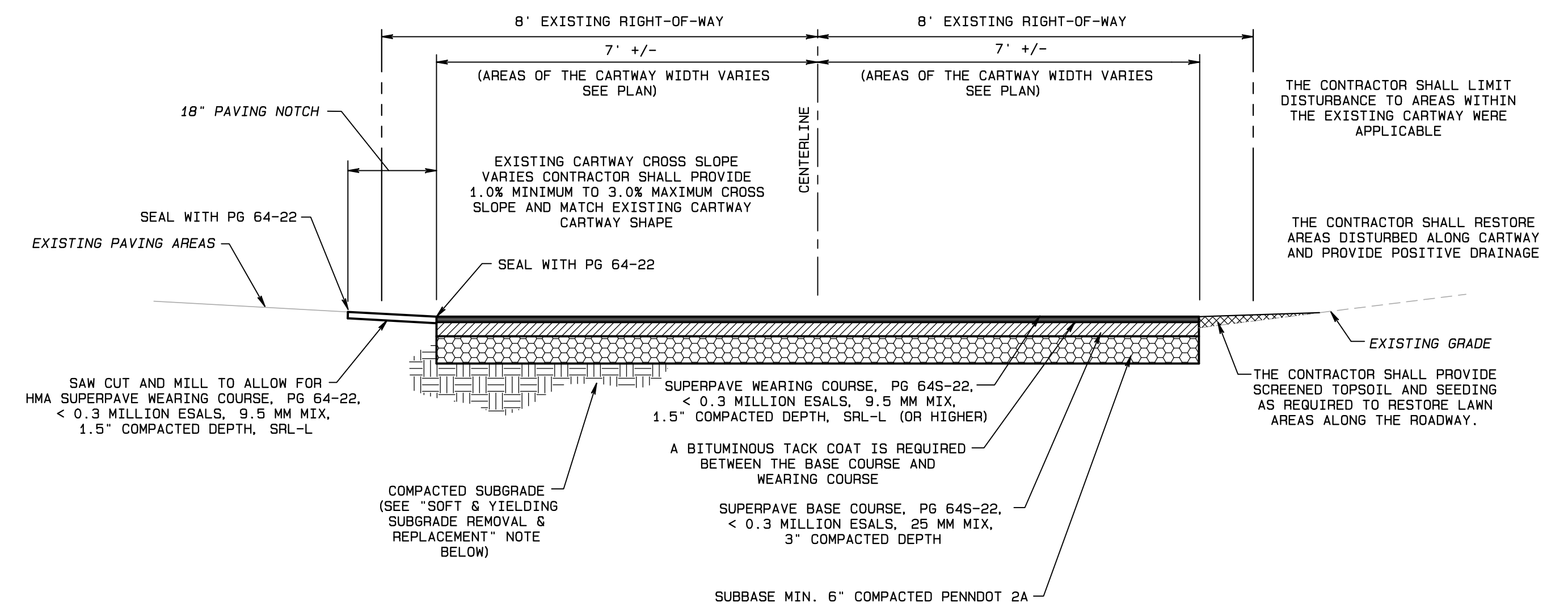

FULL DEPTH REPLACEMENT SECTIONS
NOT TO SCALE

SOFT & YIELDING SUBGRADE REMOVAL & REPLACEMENT NOTE:

WHERE SOFT & YIELDING SUBGRADE IS ENCOUNTERED, THE CONTRACTOR SHALL REMOVE AND REPLACE THE UNSUITABLE SOIL AT THE DIRECTION OF THE ENGINEER. UNSUITABLE SOIL SHALL BE REPLACED WITH #1 STONE ON A SINGLE LAYER OF PENNDOT CLASS 4-A GEOTEXTILE FABRIC. EXCAVATE 12 INCHES OF DEPTH OR AS DIRECTED BY THE ENGINEER. MEASUREMENT & PAYMENT SHALL BE PER CUBIC YARD OF MATERIAL REMOVED.

- NOTES:**
- CONTRACTOR SHALL COORDINATE WITH JONESTOWN BOROUGH TO CLOSE THE ROAD FROM THE TRAVELING PUBLIC DURING DAILY CONSTRUCTION.
 - ALL WORK SHALL BE DONE IN ACCORDANCE WITH PENNDOT PUBLICATION 408 LATEST EDITION.
 - CONTRACTOR WILL BE REQUIRED TO FURNISH ASPHALT MIX DESIGNS FOR APPROVAL PRIOR TO CONSTRUCTION.
 - PROVIDE A MILLED PAVING NOTCH WHERE NEW ASPHALT PAVING ABUTS EXISTING ASPHALT DRIVEWAYS AND AT INTERSECTING STREETS.
 - ROADWAY MAY BE CLOSED TO TRAFFIC DURING CONSTRUCTION WITH PROPER TRAFFIC CONTROL DEVICES PER PENNDOT PUBLICATIONS 212 & 213 AND THE MUTCD.
 - NO VIBRATORY COMPACTION SHALL BE PERFORMED WITHIN 10 FT OF ANY BUILDING OR SIMILAR STRUCTURE WHICH DAMAGE COULD ARISE.
 - RAISE MANHOLE COVERS AS NEEDED IN ACCORDANCE WITH NLCA REGULATIONS.

PLAN VIEW AND DETAILS

CONSTRUCTION PLANS FOR
EAST BLACKBERRY STREET IMPROVEMENTS PLAN

LOCATED IN
JONESTOWN BOROUGH, LEBANON COUNTY, PENNSYLVANIA
OWNER
BOROUGH OF JONESTOWN
295 S. MILL ST., PO BOX 446
JONESTOWN, PA 17038
(717) 861-5414

LIGHT-HEIGEL AND ASSOCIATES, INC.
ENGINEERS AND SURVEYORS
430 EAST MAIN STREET, PALMYRA, PA 17078
(717) 838-1351 FAX (717) 838-3820 1-800-257-2190 www.light-heigel.com

REGIONAL OFFICES
LANCASTER, PA HALIFAX, PA SCHUYLKILL HAVEN, PA
WEST CHESTER, PA LEWISBURG, PA



DATE: 02/03/2002 CHECKED BY: LL
SCALE: AS NOTED DRAWN BY: SML
COMP'D BY: SML FIELD: LL

DWG. NO.: PA00-0091
MAPCHECK: N/A
SHEET: 2 OF 4

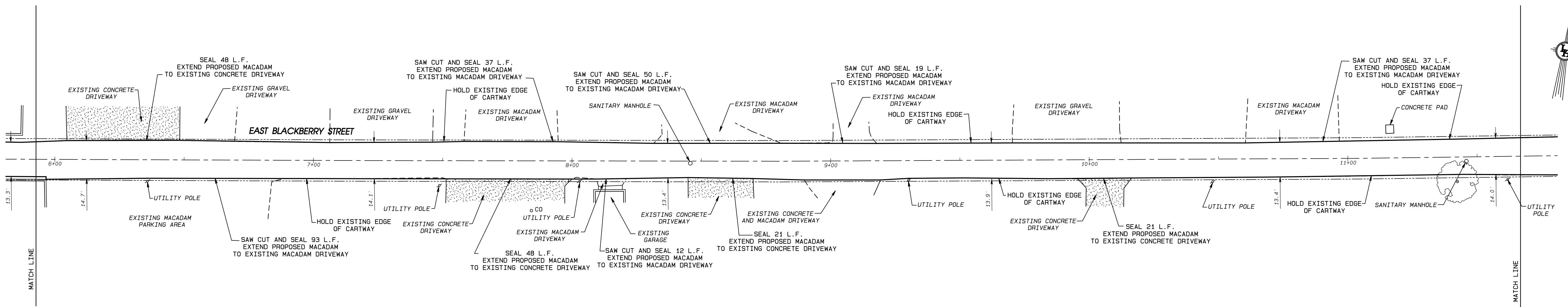

IMPROVEMENT PLAN
 HORIZONTAL SCALE 1" = 20'

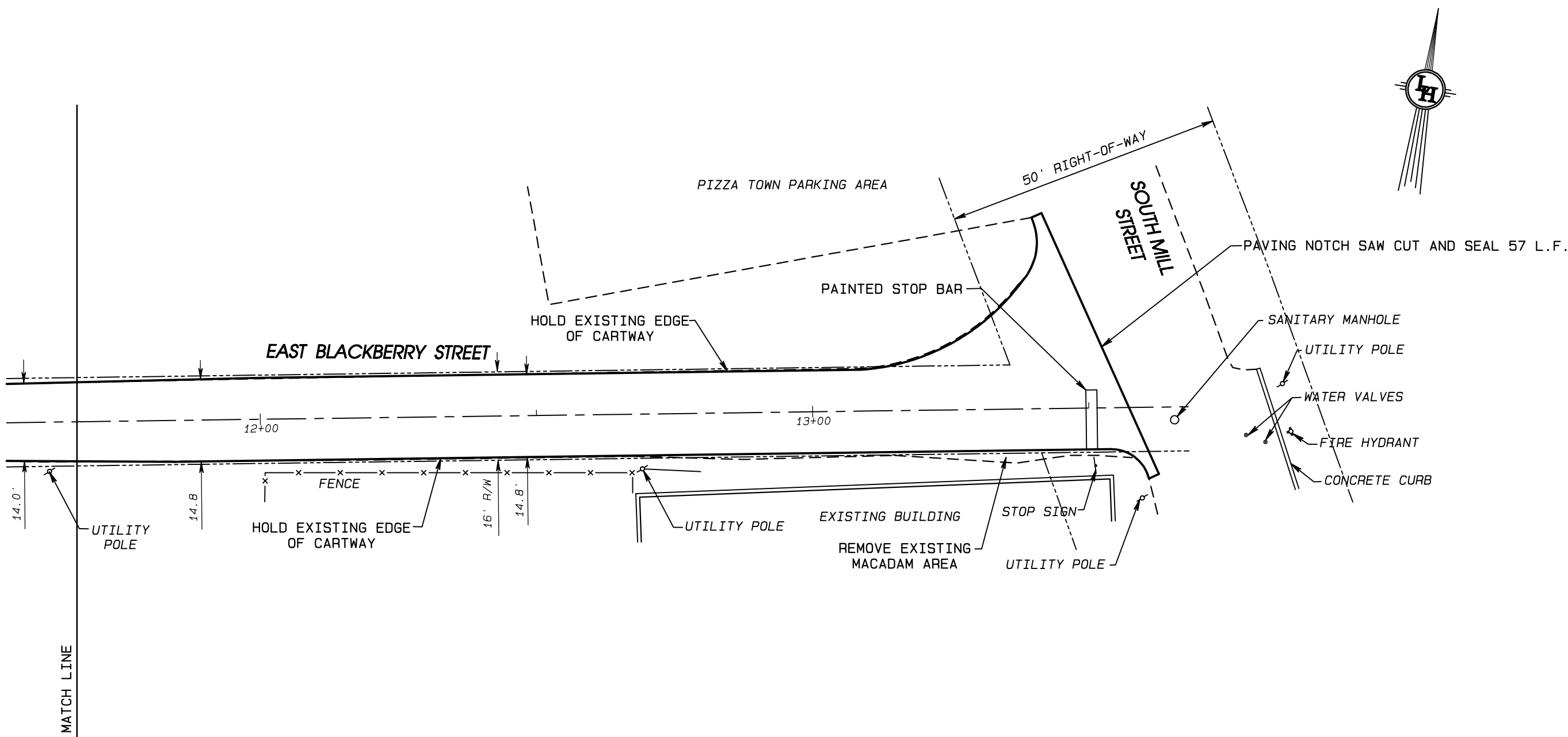

IMPROVEMENT PLAN
 HORIZONTAL SCALE 1" = 20'

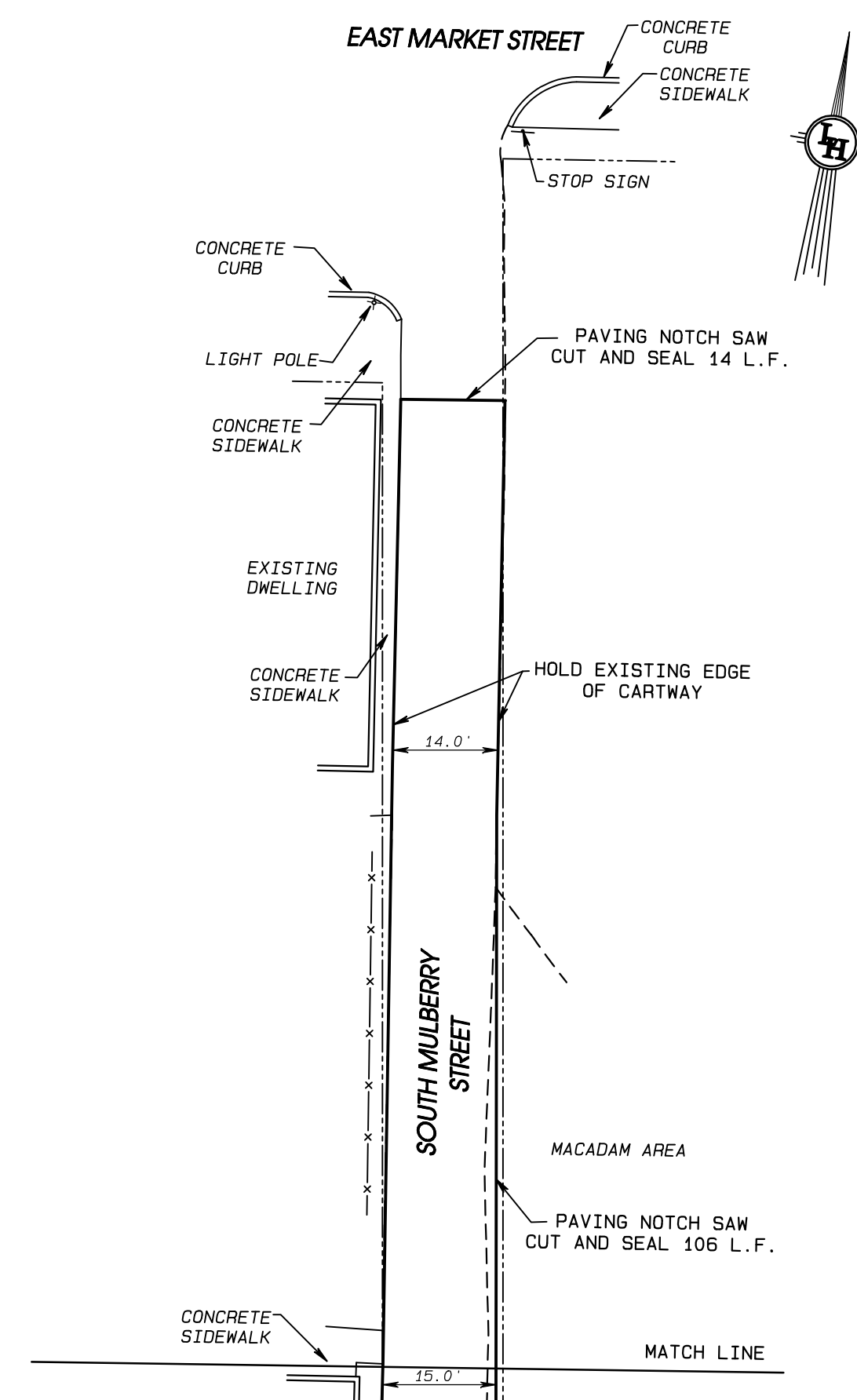

IMPROVEMENT PLAN
 HORIZONTAL SCALE 1" = 20'

PLAN VIEW AND DETAILS

CONSTRUCTION PLANS
**EAST BLACKBERRY STREET
 IMPROVEMENTS PLAN**
 LOCATED IN
 JONESTOWN BOROUGH, LEBANON COUNTY, PENNSYLVANIA
 OWNER
BOROUGH OF JONESTOWN
 295 S. MILL ST., PO BOX 446
 JONESTOWN, PA 17038
 (717) 861-5414

LIGHT-HEIGEL AND ASSOCIATES, INC.
 ENGINEERS and SURVEYORS
 430 EAST MAIN STREET, PALMYRA, PA, 17078
 (717) 838-1351 FAX (717) 838-3820 1-800-257-2190 www.light-heigel.com

REGIONAL OFFICES
 LANCASTER, PA HALIFAX, PA SCHUYLKILL HAVEN, PA
 WEST CHESTER, PA LEWISBURG, PA

DATE: 02/03/2022 CHECKED BY: LL DWS. NO.: PA00-0091
 SCALE: AS NOTED DRAWN BY: SML MAPCHECK: N/A
 COMP'D BY: SML FIELD: LL SHEET: 3 OF 4

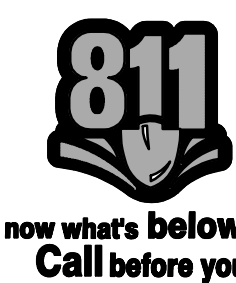

1. GENERAL SOIL EROSION AND SEDIMENTATION CONTROL NOTES

- A. A COPY OF THE EROSION AND SEDIMENT POLLUTION CONTROL PLAN MUST BE AVAILABLE AT THE SITE OF THE EARTHMOVING ACTIVITY DURING CONSTRUCTION AND UNTIL THE SITE IS STABILIZED. THE DISTRICT REQUESTS NOTIFICATION AT LEAST 10 DAYS PRIOR TO COMMENCEMENT OF ON-SITE EARTHMOVING AND MAY CONDUCT PERIODIC SITE INSPECTIONS TO DETERMINE CHAPTER 102 COMPLIANCE.
 - (LEBANON COUNTY CONSERVATION DISTRICT, PHONE NUMBER (717) 277-5275 EXT 4)
- B. STORMWATER RUNOFF FROM THE PROJECT AREA DRAINS TO AN UNNAMED TRIBUTARY TO THE SWATARA CREEK.
- C. DEVELOPMENT SHALL PRESERVE SALIENT NATURAL FEATURES, MINIMIZE LAND CUTS AND FILLS, AND CONFORM TO THE GENERAL TOPOGRAPHY SO AS TO CREATE THE LEAST EROSION POTENTIAL, AND TO ADEQUATELY CONTAIN THE VOLUME AND VELOCITY OF SURFACE WATER RUNOFF.
- D. SEDIMENT IN THE RUNOFF WATER SHALL BE TRAPPED UNTIL ALL THE DISTURBED AREA IS STABILIZED. DISTURBED AREAS, AND THE DURATION OF EXPOSURE THEREOF, SHALL BE KEPT TO A MINIMUM.
- E. NATURAL VEGETATION SHALL BE RETAINED, PROTECTED, AND SUPPLEMENTED. STRUCTURAL EROSION CONTROL AND DRAINAGE MEASURES SHALL BE INSTALLED PRIOR TO AND MAINTAINED DURING CONSTRUCTION.
- F. DISTURB ONLY WHEN READY FOR CONSTRUCTION AND THEN ONLY IN AREAS OF PROPOSED CONSTRUCTION.
- G. MINIMIZE AREA DISTURBED BY LIMITING WORK AREA TO THAT NECESSARY TO PERFORM WORK FOR THAT PARTICULAR DAY.
- H. MINIMIZE EXPOSURE OF BARE EARTH BY PROPER SCHEDULING OF MAN-POWER, EQUIPMENT AND MINIMIZE EROSION FROM EXPOSED AREAS BY STABILIZING EXPOSED AREAS IMMEDIATELY WITH EITHER TEMPORARY OR PERMANENT SEEDING. (SEE SEEDING NOTES WHICH FOLLOW).
- I. KEEP DUST WITHIN TOLERABLE LIMITS BY USING WATER OR OTHER DUST SUPPRESSORS APPROVED BY REGULATORY AGENCIES LOCATE EQUIPMENT REPAIR AND MAINTENANCE AREAS TO PREVENT CHEMICALS, FUELS, LUBRICANTS, ETC. FROM DISCHARGING INTO STREAMS, WELLS, OR SPRINGS.
- J. SEDIMENT CLEARED FROM EROSION AND SEDIMENTATION DEVICES IS TO BE SPREAD OVER NEXT AREA TO BE SEEDER OR PLACED ON THE SOIL STOCKPILE AREA.
- K. THE CONTRACTOR WILL BE RESPONSIBLE FOR THE PROPER CONSTRUCTION, STABILIZATION, AND MAINTENANCE OF ALL EROSION AND SEDIMENTATION CONTROLS.
- L. SHOULD ANY MEASURES CONTAINED WITHIN THIS PLAN PROVE INCAPABLE OF ADEQUATELY REMOVING SEDIMENT FROM ON-SITE FLOWS PRIOR TO DISCHARGE OR OF STABILIZING THE SURFACES INVOLVED, ADDITIONAL MEASURES MUST BE IMMEDIATELY IMPLEMENTED BY THE CONTRACTOR TO ELIMINATE ALL SUCH PROBLEMS.
- M. EROSION AND SEDIMENTATION BMPs MUST BE STABILIZED IMMEDIATELY.
- N. ONLY LIMITED DISTURBANCE WILL BE PERMITTED TO PROVIDE ACCESS TO THE SITE FOR GRADING AND ACQUIRING BORROW TO CONSTRUCT EGS CONTROLS.
- O. EROSION AND SEDIMENTATION CONTROLS MUST BE CONSTRUCTED, STABILIZED, AND FUNCTIONAL BEFORE SITE DISTURBANCE WITHIN THE TRIBUTARY AREAS OF EGS CONTROLS.
- P. AFTER FINAL SITE STABILIZATION HAS BEEN ACHIEVED, TEMPORARY EROSION AND SEDIMENTATION CONTROLS MUST BE REMOVED. AREAS DISTURBED DURING REMOVAL OF THE CONTROLS MUST BE STABILIZED IMMEDIATELY.
- Q. MUD, SILT AND/OR SEDIMENT SHALL BE REMOVED FROM VEHICLES & EQUIPMENT PRIOR TO EXITING THE SITE, BY MECHANICAL MEANS.
- R. FILTER FABRIC FENCE OR SILT SOCK MUST BE INSTALLED AT LEVEL GRADE. BOTH ENDS OF EACH FENCE OR SILT SOCK SECTION MUST EXTEND AT LEAST 10 FEET UP SLOPE AT 45 DEGREES TO THE MAIN FENCE OR SOCK ALIGNMENT.
- S. ANY FILTER FENCE OR SILT SOCK WHICH HAS BEEN UNDERMINED OR TOPPED MUST BE IMMEDIATELY REPLACED WITH A ROCK FILTER OUTLET. SEE ROCK FILTER OUTLET DETAIL.
- T. UNTIL THE SITE IS STABILIZED, ALL EROSION AND SEDIMENT BMPs MUST BE MAINTAINED PROPERLY. MAINTENANCE MUST INCLUDE INSPECTIONS OF ALL EROSION AND SEDIMENT BMPs AFTER EACH RUNOFF EVENT AND ON A WEEKLY BASIS. ALL PREVENTATIVE AND REMEDIAL MAINTENANCE WORK, INCLUDING CLEAN OUT, REPAIR, REPLACEMENT, REGRADING, RESEEDING, REMULCHING AND RENETTING MUST BE PERFORMED IMMEDIATELY. IF EROSION AND SEDIMENT CONTROL BMPs FAIL TO PERFORM AS EXPECTED, REPLACEMENT BMPs, OR MODIFICATIONS TO THOSE INSTALLED WILL BE REQUIRED.

2. BORROW, FILL AND WASTE MATERIALS

- A. ALL STOCKPILES OF SOIL MAY BE PLACED TEMPORARILY IN THE JONESTOWN BOROUGH REFUSE STOCKPILE AREA LOCATED SOUTH OF THE JONESTOWN BOROUGH HALL BUILDING. THE CONTRACTOR SHALL MAKE ARRANGEMENTS WITH THE JONESTOWN BOROUGH MAINTENANCE DEPARTMENT BEFORE PLACING ANY MATERIAL. MATERIAL MUST BE REMOVED AFTER COMPLETION OF THE PROJECT.
- B. THE SOIL STOCKPILE MAY NOT EXCEED 35' IN HEIGHT NOR HAVE SIDE SLOPES GREATER THAN 2:1.
- C. ALL BUILDING MATERIALS AND WASTES MUST BE REMOVED FROM THE SITE AND RECYCLED OR DISPOSED IN ACCORDANCE WITH THE DEPARTMENT'S SOLID WASTE MANAGEMENT REGULATIONS AT 25 PA. CODE SECTION 260.1 et seq., SECTION 271.1 et seq., AND 287.1 et seq. NO BUILDING MATERIAL OR WASTES OR UNUSED BUILDING MATERIALS SHALL BE BURIED, DUMPED, OR DISCHARGED AT THE SITE.
- D. BURNING - DO NOT BURN WASTE MATERIAL IN AREAS PROHIBITED BY FEDERAL, STATE AND/OR LOCAL LAWS. WHERE BURNING IS PERMITTED, BURN IN ACCORDANCE WITH APPLICABLE PROVISIONS OF REGULATING AGENCIES.

3. CONSTRUCTION SEQUENCE

- 1. PRIOR TO COMMENCEMENT OF ANY EARTHWORK, THE CONTRACTOR SHALL PERFORM THE FOLLOWING:
 - A. NOTIFICATION - THE CONTRACTOR SHALL NOTIFY THE FOLLOWING

LEBANON COUNTY CONSERVATION DISTRICT 2120 CORNWALL ROAD, SUITE 5 LEBANON, PA 17042 PHONE: (717) 277-5274 EXT. 4	BOROUGH OF JONESTOWN 295 S. MILL ST., PO BOX 446 JONESTOWN, PA 17038 PHONE: (717) 861-5414
LIGHT-HEIGEL AND ASSOCIATES, INC. 430 EAST MAIN STREET PALMYRA, PA 17078 PHONE: (717) 838-1351	PENNSYLVANIA ONE CALL SYSTEM, INC. PHONE: (800) 242-1776
- 2. SOIL STOCKPILE: PRIOR TO EXCAVATION ACTIVITIES, CONTRACTOR SHALL CONTACT JONESTOWN BOROUGH DEPARTMENT TO DETERMINE A SUITABLE TEMPORARY FACILITY AT THE GREENWASTE DISPOSAL SITE ON LANDS OF JONESTOWN BOROUGH TO ACCEPT EXCAVATION MATERIALS, INCLUDING, BUT NOT LIMITED TO VEGETATION, SOIL, STONE, CONCRETE, AND MACADAM. CONTRACTOR SHALL BE RESPONSIBLE FOR REMOVING ALL STOCKPILE AND DEBRIS IN COMPLIANCE WITH FEDERAL, STATE, AND LOCAL REGULATIONS. AFTER CONSTRUCTION CONTRACTOR SHALL ALSO BE RESPONSIBLE FOR VERIFICATION THAT EXCAVATION MATERIALS ARE CLEAN AND SAFE, IF NOT TRANSPORTED TO A LANDFILL; AND FOR ANALYTICAL TESTING OF MATERIALS, IF REQUIRED. CONSTRUCTION VEHICLES SHALL USE THE AREA INDICATED ON THE PLANS AS THE CONSTRUCTION VEHICLE WASHDOWN AREA. TO REMOVE EXCESS DEBRIS FROM THE VEHICLES PRIOR TO EXITING THE SITE.
- 3. CLEARLY MARK THE LIMITS OF DISTURBANCE AND PLACE EROSION AND SEDIMENT CONTROLS WHERE SHOWN ON THE PLAN. INSTALL ALL SOIL EROSION FEATURES.
- 4. CONSTRUCT THE PROJECT, BEGINNING WITH DEMOLITION/EXCAVATION OF THE EXISTING ROADWAY. PERFORM ROAD CONSTRUCTION, SEEDING/STABILIZATION.
- 5. WHEN INSTALLATION IS COMPLETE AND DISTURBED AREAS HAVE BEEN STABILIZED REMOVE EGS CONTROLS.

4. SEEDING SPECIFICATIONS

- A. TEMPORARY SEEDING - IF PERMANENT VEGETATION IS NOT PLACED ON THE DISTURBED AREA IMMEDIATELY, THE DISTURBED AREA SHALL BE SEEDER AS FOLLOWS.

- 1. IF SOIL TEST RESULTS ARE NOT AVAILABLE, APPLY AGRICULTURAL GRADE LIME AT A RATE OF 1 TON/ACRE, OR 50 LBS./1,000 S.F., AND FERTILIZER 10-20-20 AT RATE OF 500 LBS./ACRE, OR 25 LBS./1,000 S.F.
- 2. BROADCAST A TEMPORARY SEED MIXTURE OF ANNUAL RYEGRASS AT A RATE OF 40 LBS./ACRE, OR 1 LB./1,000 S.F.
- 3. SPREAD MULCH (STRAW OR HAY) AT A RATE OF 3 TONS/ACRE, OR 140 LBS./1,000 S.F.
- 4. ANCHOR IMMEDIATELY. MULCH SHALL BE ANCHORED WITH WOOD CELLULOSE FIBER (APPLIED AT A RATE OF 1,000 LBS./ACRE) OR OTHER SUITABLE MULCH ANCHORING MATERIAL.

- B. PERMANENT SEEDING
 - 1. PLACE TOPSOIL TO A MINIMUM DEPTH OF 6 INCHES WHERE THE TEXTURE OF THE EXPOSED SOIL IS NOT SUITABLE FOR VEGETATIVE GROWTH, OR WHERE THE TOPSOIL DEPTH IS INSUFFICIENT FOR THE SUPPORTING ROOT ZONE.
 - 2. LIME AND FERTILIZER ACCORDING TO SOIL TESTS, OR AT THE RATES INDICATED BELOW.
 - 3. LOOSEN SURFACE SOIL TO A DEPTH OF 4 TO 6 INCHES WITH SUITABLE EQUIPMENT. APPLY SEEDS UNIFORMLY BY BROADCASTING OR HYDROSEEDING.
 - 4. MULCH ALL AREAS AS INDICATED BELOW.
 - 5. ANCHOR IMMEDIATELY AS INDICATED BELOW.
- C. APPLICATION RATES
 - A. SEED AND SOIL AMENDMENT APPLICATION RATES-SLOPE < 3:1
 - 1) APPLY AGRICULTURAL GRADE LIME AT A RATE OF 4 TONS/ACRE, OR 190 LBS./1,000 S.F.
 - 2) APPLY FERTILIZER 10-20-20 AT A RATE OF 500 LBS./ACRE, OR 12 LBS./1,000 S.F.
 - 3) BROADCAST A PERMANENT SEED MIXTURE OF 50 PERCENT FINE FESCUE (2 VARIETIES), 40 PERCENT PERENNIAL RYEGRASS (2 VARIETIES), AND 10 PERCENT KENTUCKY BLUEGRASS (2 VARIETIES) AT A RATE OF 160 LBS./ACRE, OR 4 LBS./1,000 S.F.; AND
 - 4) SPREAD MULCH (STRAW OR HAY) AT A RATE OF 3 TONS/ACRE, OR 140 LBS./1,000 S.F.
 - 5) MULCH SHALL BE ANCHORED WITH WOOD CELLULOSE FIBER (APPLIED AT A RATE OF 1,000 LBS./ACRE) OR OTHER SUITABLE MULCH ANCHORING MATERIAL.
 - B. SEED AND SOIL AMENDMENT APPLICATION RATES-SLOPE > 3:1
 - 1) APPLY AGRICULTURAL LIME AT A RATE OF 4 TONS/ACRE, OR 190 LBS./1,000 S.F.
 - 2) APPLY FERTILIZER 10-20-20 AT A RATE OF 1,000 LBS./ACRE, OR 25 LBS./1,000 S.F.
 - 3) BROADCAST A PERMANENT SEED MIXTURE OF 100% TALL FESCUE 31 AT A RATE OF 160 LBS./ACRE, OR 4 LBS./1,000 S.F.
 - 4) SPREAD MULCH (STRAW/HAY) AT A RATE OF 3 TONS/ACRE, OR 140 LBS./1,000 S.F.
 - 5) MULCH SHALL BE ANCHORED WITH WOOD CELLULOSE FIBER (APPLIED AT A RATE OF 1,000 LBS./ACRE) OR OTHER SUITABLE MULCH ANCHORING MATERIAL. APPLY PROTECTIVE NETTING AFTER MULCHING.
- D. RAIN GARDEN BOTTOMS
 - 1) BROADCAST A PERMANENT RAIN GARDEN SEEDING MIX. (USE ERNST CONSERVATION SEEDS - MIX ERNWX180.) AT A RATE OF 45 LBS PER ACRE, OR 1/2 TO 1/2 LB PER 1,000 S.F. THE MOST SUITABLE PLANTING SEASON IS FROM MARCH 15 TO JUNE 15. ALTERNATELY, A DORMANT PLANTING MAY BE PERFORMED IN LATE FALL, APPROXIMATELY BETWEEN NOVEMBER 15 TO DECEMBER 15. (SEE POST-CONSTRUCTION STORMWATER MANAGEMENT PLAN FOR ADDITIONAL SPECIFICATIONS ON ENGINEERED SOIL REQUIREMENTS.)
 - 2) IN THE FIRST AND SECOND YEAR OF GROWTH, CROP VEGETATION TO 6"-10" IN HEIGHT APPROXIMATELY FOUR TIMES OVER THE SPRING THROUGH SUMMER GROWING SEASON.

5. DEGREE OF COVERAGE REQUIREMENTS

- A. IF A MINIMUM UNIFORM 70% PERENNIAL VEGETATIVE COVER IS NOT ESTABLISHED ON ALL LAIN AREAS BY OCTOBER 15, THE CONTRACTOR SHALL LOOSEN THE SOIL SURFACE AND APPLY ADDITIONAL TOPSOIL, AND APPLY SOIL AMENDMENTS, SEED AND MULCH TO THE EXTENT REQUIRED TO ESTABLISH ADEQUATE COVER.
- B. IF A UNIFORM 90 PERCENT COVER IS NOT ESTABLISHED ON ALL SLOPES BY OCTOBER 15, ALL BARREN AREAS SHALL BE REPLANTED IN ACCORDANCE WITH THE DIRECTIONS IN ITEM 4 AS APPROPRIATE.
- C. ALL VEGETATION SHALL BE GUARANTEED TO ACHIEVE 100 PERCENT COVERAGE WITHIN ONE YEAR, OR PLANTING SHALL CONTINUE UNTIL 100 PERCENT COVERAGE IS ACHIEVED.
- D. PERMANENT STABILIZATION REQUIREMENTS FOR AN EARTH DISTURBANCE ACTIVITY OR ANY STAGE OR PHASE OF AN ACTIVITY TO BE CONSIDERED PERMANENTLY STABILIZED, THE DISTURBED AREAS SHALL BE COVERED WITH ONE OF THE FOLLOWING
 - 1) A MINIMUM UNIFORM 70% PERENNIAL VEGETATIVE COVER, WITH A DENSITY CAPABLE OF RESISTING ACCELERATED EROSION AND SEDIMENTATION, OR
 - 2) AN ACCEPTABLE BMP WHICH PERMANENTLY MINIMIZES ACCELERATED EROSION AND SEDIMENTATION.

6. MAINTENANCE OF DEVICES

- A. THE CONTRACTOR MUST ENSURE THAT VISUAL SITE INSPECTIONS ARE CONDUCTED WEEKLY, AND AFTER EACH PRECIPITATION EVENT BY QUALIFIED PERSONNEL, TRAINED AND EXPERIENCED IN EROSION AND SEDIMENT CONTROL, TO ASCERTAIN THAT THE BMP'S ARE OPERATIONAL AND EFFECTIVE IN PREVENTING POLLUTION TO THE WATERS OF THE COMMONWEALTH. A WRITTEN REPORT OF EACH INSPECTION SHALL BE KEPT, AND INCLUDE:
 - (1) A SUMMARY OF SITE CONDITIONS, BMP'S, AND COMPLIANCE; AND
 - (2) THE DATE, TIME AND THE NAME OF THE PERSON CONDUCTING THE INSPECTION.
- B. SEDIMENT DEPOSITS SHOULD BE REMOVED AFTER EACH RAINFALL. SEDIMENT MUST BE REMOVED AS INDICATED BELOW. REMOVED DEPOSITS SHALL BE SPREAD UNIFORMLY ON THE SITE AWAY FROM CONSTRUCTION AND ABOVE CONTROL DEVICES. ANY DEPOSITS REMAINING IN PLACE AFTER THE DEVICES ARE NO LONGER REQUIRED MAY BE DRESSED, PREPARED TO CONFORM TO THE EXISTING GRADE AND SEEDER, OR HAULED TO AN OFFSITE FACILITY WITH AN APPROVED EROSION AND SEDIMENT CONTROL PLAN.
 - SILT FENCE OR SILT SOCK - SILT FENCE OR SILT SOCK TO BE CLEANED ONCE SEDIMENT LEVEL REACHES 1/2 THE FENCE/SOCK HEIGHT.
 - INLET FILTER BAGS - INLET FILTER BAGS TO BE CLEANED AS REQUIRED BY MANUFACTURERS RECOMMENDATION.
- C. REDUCTION, LOSS, OR FAILURE OF THE BMP'S: UPON REDUCTION, LOSS OR FAILURE OF THE BMP'S, THE CONTRACTOR SHALL TAKE IMMEDIATE ACTION TO RESTORE THE BMP'S OR PROVIDE AN ALTERNATIVE METHOD OF TREATMENT.
- D. IF THE POTENTIAL EXISTS FOR CAUSING ACCIDENTAL POLLUTION OF AIR, LAND, OR WATER OR FOR CAUSING ENDANGERMENT OF PUBLIC HEALTH AND SAFETY THROUGH ACCIDENTAL RELEASE OF TOXIC, HAZARDOUS, OR OTHER POLLUTING MATERIALS; THE CONTRACTOR MUST DEVELOP A PREPAREDNESS, PREVENTION, AND CONTINGENCY (PPC) PLAN. THE PPC PLAN SHALL BE DEVELOPED IN ACCORDANCE WITH DEPARTMENT REGULATIONS. THE PPC PLAN SHALL IDENTIFY AREAS WHICH MAY INCLUDE, BUT ARE NOT LIMITED TO, WASTE MANAGEMENT AREAS, RAW MATERIAL STORAGE AREAS, TEMPORARY AND PERMANENT SPOILS STORAGE AREAS, MAINTENANCE AREAS, AND ANY OTHER AREAS THAT MAY HAVE THE POTENTIAL TO CAUSE NON-COMPLIANCE WITH THE TERMS AND CONDITIONS OF THIS PERMIT DUE TO THE STORAGE, HANDLING, OR DISPOSAL OF ANY TOXIC OR HAZARDOUS SUBSTANCES SUCH AS OIL, GASOLINE, PESTICIDES, HERBICIDES, SOLVENTS, ETC. BMP'S SHALL BE DEVELOPED AND IMPLEMENTED FOR EACH IDENTIFIED AREA. THIS PLAN SHALL BE MAINTAINED ON SITE AT ALL TIMES AND SHALL BE MADE AVAILABLE FOR REVIEW AT THE COUNTY CONSERVATION DISTRICT'S REQUEST.

ORGANIC MATTER CONTENT	80% - 100% (DRY WEIGHT BASIS)
ORGANIC PORTION	FIBROUS AND ELONGATED
pH	5.5 - 8.0
MOISTURE CONTENT	35% - 55%
PARTICLE SIZE	98% PASS THROUGH 1" SCREEN
SOLUBLE SALT CONCENTRATION	5.0 dg/m DMMS/CM MAXIMUM

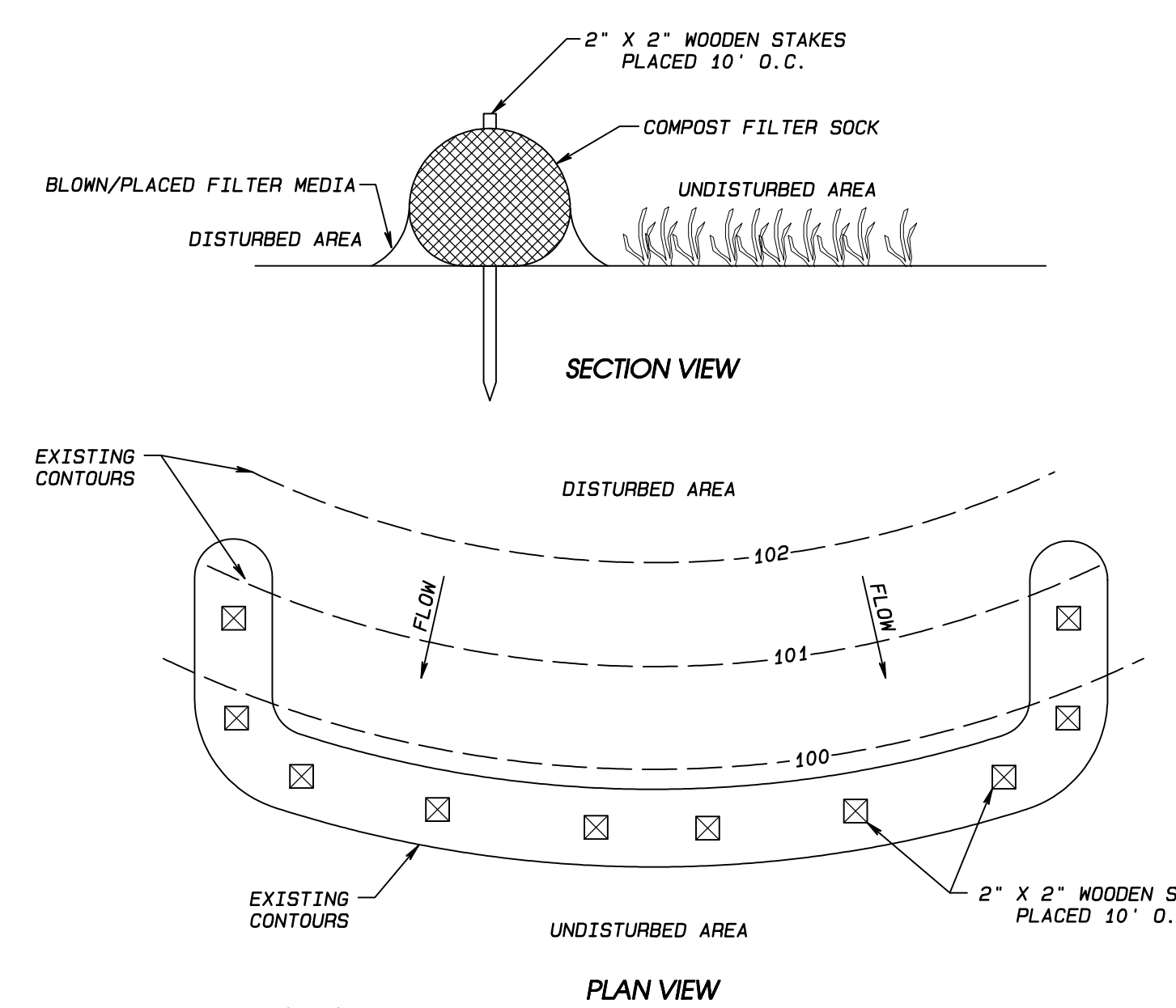

NOTES:
 SOCK FABRIC SHALL MEET STANDARDS OF TABLE 4.1. COMPOST SHALL MEET THE STANDARDS OF TABLE 4.2.
 COMPOST FILTER SOCK SHALL BE PLACED AT EXISTING LEVEL GRADE. BOTH ENDS OF THE SOCK SHALL BE EXTENDED AT LEAST 9 FEET UP-SLOPE AT 45 DEGREES TO THE MAIN SOCK ALIGNMENT (FIGURE 4.1). MAXIMUM SLOPE LENGTH ABOVE ANY SOCK SHALL NOT EXCEED THAT SHOWN ON FIGURE 4.2. STAKES MAY BE INSTALLED IMMEDIATELY DOWNSLOPE OF THE SOCK IF SO SPECIFIED BY THE MANUFACTURER.
 TRAFFIC SHALL NOT BE PERMITTED TO CROSS FILTER SOCKS.
 ACCUMULATED SEDIMENT SHALL BE REMOVED WHEN IT REACHES HALF THE ABOVEGROUND HEIGHT OF THE SOCK AND DISPOSED IN THE MANNER DESCRIBED ELSEWHERE IN THE PLAN.
 SOCKS SHALL BE INSPECTED WEEKLY AND AFTER EACH RUNOFF EVENT. DAMAGED SOCKS SHALL BE REPAIRED ACCORDING TO MANUFACTURER'S SPECIFICATIONS OR REPLACED WITHIN 24 HOURS OF INSPECTION.

BIODEGRADABLE FILTER SOCKS SHALL BE REPLACED AFTER 6 MONTHS; PHOTODEGRADABLE SOCKS AFTER 1 YEAR. POLYPROPYLENE SHOCKS SHALL BE REPLACED ACCORDING TO MANUFACTURER'S SPECIFICATIONS.
 UPON STABILIZATION OF THE AREA TRIBUTARY TO THE SOCK, STAKES SHALL BE REMOVED, THE SOCK MAY BE LEFT IN PLACE AND VEGETATED OR REMOVED. IN THE LATTER CASE, THE MESH SHALL BE CUT OPEN AND THE MULCH SPREAD AS A SOIL SUPPLEMENT.

COMPOST FILTER SOCK
 NOT TO SCALE

MATERIAL TYPE	3 MIL HDPE	5 MIL HDPE	5 MIL HDPE	MULTI-FILAMENT POLYPROPYLENE (MPPF)	HEAVY DUTY MULTI-FILAMENT POLYPROPYLENE (HDMPFP)
MATERIAL CHARACTERISTICS	PHOTO-DEGRADABLE	PHOTO-DEGRADABLE	BIO-DEGRADABLE	PHOTO-DEGRADABLE	PHOTO-DEGRADABLE
SOCK DIAMETERS	18" 18"	12" 24" 18" 32"	12" 24" 18" 32"	12" 24" 18" 32"	12" 24" 18" 32"
MESH OPENING	3/8"	3/8"	3/8"	3/8"	1/8"
TENSILE STRENGTH		26 PSI	26 PSI	44 PSI	202 PSI
ULTRAVIOLET STABILITY % ORIGINAL STRENGTH (ASTM G-155)	23% AT 1000 HR.	23% AT 1000 HR.		100% AT 1000 HR.	100% AT 1000 HR.
MINIMUM FUNCTIONAL LONGEVITY	6 MONTHS	9 MONTHS	6 MONTHS	1 YEAR	2 YEARS
TWO-PLY SYSTEMS					
INNER CONTAINMENT NETTING	HDPE BIAxIAL NET				
	CONTINUOUSLY WOUND FUSION-WELDED JUNCTURES				
OUTER FILTRATION MESH	3/4" X 3/4" MAX. APERTURE SIZE				
	COMPOSITE POLYPROPYLENE FABRIC (WOVEN LAYER AND NON-WOVEN FLEECE MECHANICALLY FUSED VIA NEEDLE PUNCH) 3/16" MAX. APERTURE SIZE				
SOCK FABRICS COMPOSED OF BURLAP MAY BE USED ON PROJECTS LASTING 6 MONTHS OR LESS.					

NORTH AMERICAN GREEN SPECIFICATIONS (S 75)

THE EROSION CONTROL BLANKET SHALL BE A MACHINE-PRODUCED MAT OF 100% AGRICULTURAL STRAW WITH A FUNCTIONAL LONGEVITY OF APPROXIMATELY 12 MONTHS.
 THE BLANKET SHALL BE OF CONSISTENT THICKNESS WITH THE STRAW EVENLY DISTRIBUTED OVER THE ENTIRE AREA OF THE MAT. THE BLANKET SHALL BE COVERED ON THE TOP SIDE WITH A LIGHTWEIGHT PHOTODEGRADABLE POLYPROPYLENE NETTING HAVING AN APPROXIMATE 0.50 X 0.50 (1.27 X 1.27 CM) MESH, AND BE SEWN TOGETHER ON 1.50 INCH (3.81 CM) CENTERS (50 STITCHES PER ROLL WIDTH WITH DEGRADABLE THREAD).
 THE BLANKET SHALL BE MANUFACTURED WITH A COLORED LINE OR THREAD STITCHED ALONG BOTH OUTER EDGES (APPROXIMATELY 2-5 INCHES (5 - 12.5 CM) FROM THE EDGE) TO ENSURE PROPER MATERIAL OVERLAPPING.
 STRAW EROSION CONTROL BLANKET SHALL BE S75 AS MANUFACTURED BY NORTH AMERICAN GREEN, OR EQUIVALENT. THE S75 EROSION CONTROL BLANKET SHALL HAVE THE FOLLOWING PROPERTIES:
 MATERIAL CONTENT
 MATRIX 100% STRAW FIBER (0.50 LBS / YD²) (0.27 KG / M²)
 NETTING ONE SIDE ONLY, LIGHTWEIGHT PHOTODEGRADABLE (2.10 LBS / 1,000 FT² [1.02 KG / 100M²] APPROXIMATE WEIGHT)
 THREAD DEGRADABLE
 PHYSICAL SPECIFICATIONS (PER ROLL)

ENGLISH	METRIC
WIDTH 6.67 FT	2.03 M
LENGTH 108.00 FT	36.92 M
WEIGHT 40.00 LBS ± 10%	18.14 KG
AREA 80.00 YD ²	66.89 M ²
STITCH SPACING 1.50 INCHES	3.81 CM

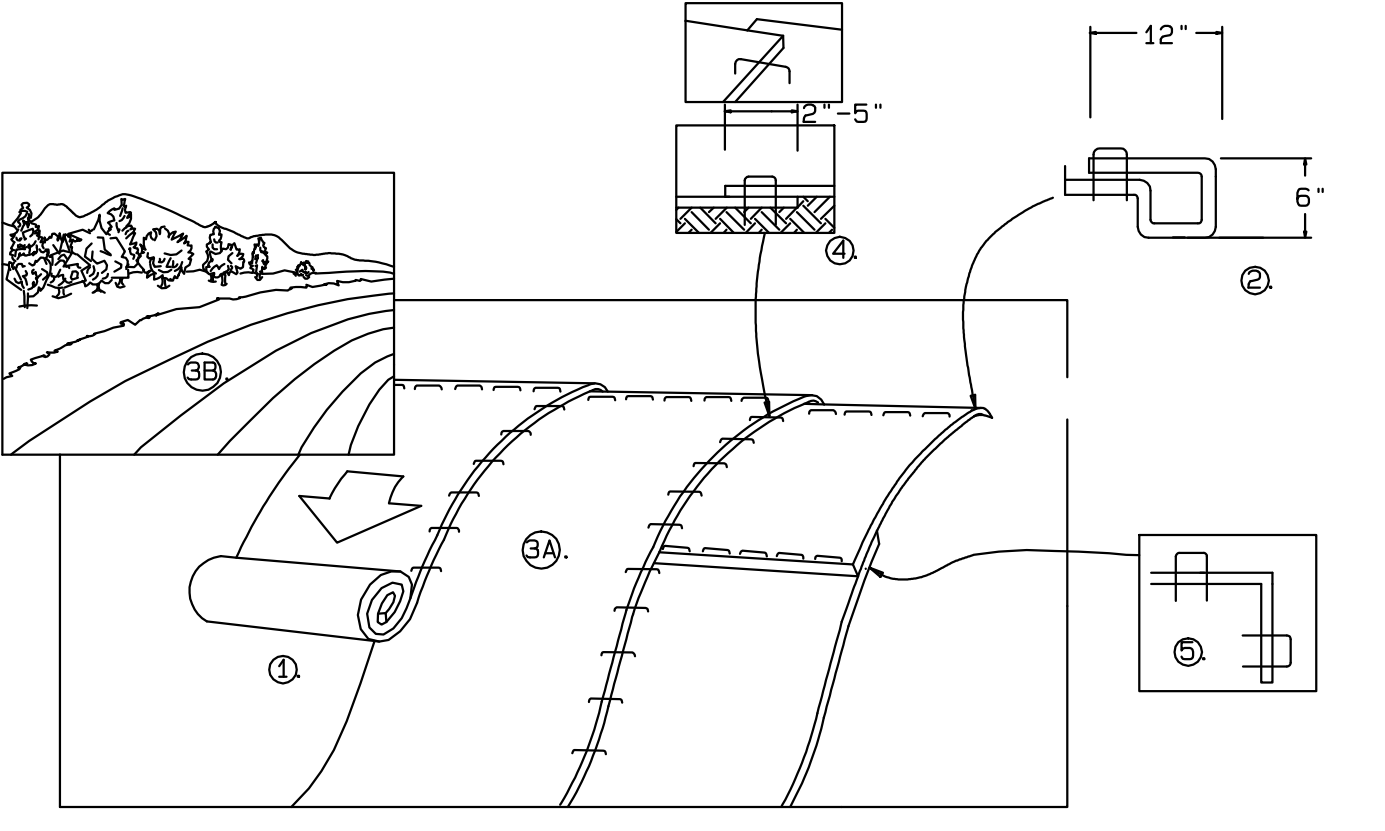

NORTH AMERICAN GREEN SLOPE LINING INSTRUCTIONS

- 1. PREPARE SOIL BEFORE INSTALLING ROLLED EROSION CONTROL PRODUCTS (REOPS), INCLUDING ANY NECESSARY APPLICATION OF LIME, FERTILIZER AND SEED.
- 2. BEGIN AT THE TOP OF THE SLOPE BY ANCHORING THE REOPS IN A 6" (15 CM) DEEP X 6" (15 CM) WIDE TRENCH WITH APPROXIMATELY 12" (30 CM) OF REOPS EXTENDED BEYOND THE UP-SLOPE PORTION OF THE TRENCH. ANCHOR THE REOPS WITH A ROW OF STAPLES/STAKES APPROXIMATELY 12" (30 CM) APART IN THE BOTTOM OF THE TRENCH. BACKFILL AND COMPACT THE TRENCH AFTER STAPLING. APPLY SEED TO COMPACTED SOIL AND FOLD REMAINING 12" (30 CM) PORTION OF REOPS BACK OVER SEED AND COMPACTED SOIL. SECURE REOPS OVER COMPACTED SOIL WITH A ROW OF STAPLES/STAKES SPACED APPROXIMATELY 12" (30 CM) APART ACROSS THE WIDTH OF THE REOPS.
- 3. ROLL THE REOPS (A) DOWN OR (B) HORIZONTALLY ACROSS THE SLOPE. REOPS WILL UNROLL WITH APPROPRIATE SIDE AGAINST THE SOIL SURFACE. ALL REOPS MUST BE SECURELY FASTENED TO SOIL SURFACE BY PLACING STAPLES/STAKES IN APPROPRIATE LOCATIONS AS SHOWN IN THE STAPLE PATTERN GUIDE. WHEN USING THE DOT SYSTEM, STAPLES/STAKES SHOULD BE PLACED THROUGH EACH OF THE COLORED DOTS CORRESPONDING TO THE APPROPRIATE STAPLE PATTERN.
- 4. THE EDGES OF PARALLEL REOPS MUST BE STAPLED WITH APPROXIMATELY 2" (5 CM) (5 CM X 12.5 CM) OVERLAP DEPENDING ON REOP S TYPE.
- 5. CONSECUTIVE REOPS SPICED DOWN THE SLOPE MUST BE PLACED END OVER END (SHINGLE STYLE) WITH AN APPROXIMATE 3" (7.5 CM) OVERLAP. STAPLE THROUGH OVERLAPPED AREA, APPROXIMATELY 12" (30 CM) APART ACROSS ENTIRE REOP'S WIDTH.

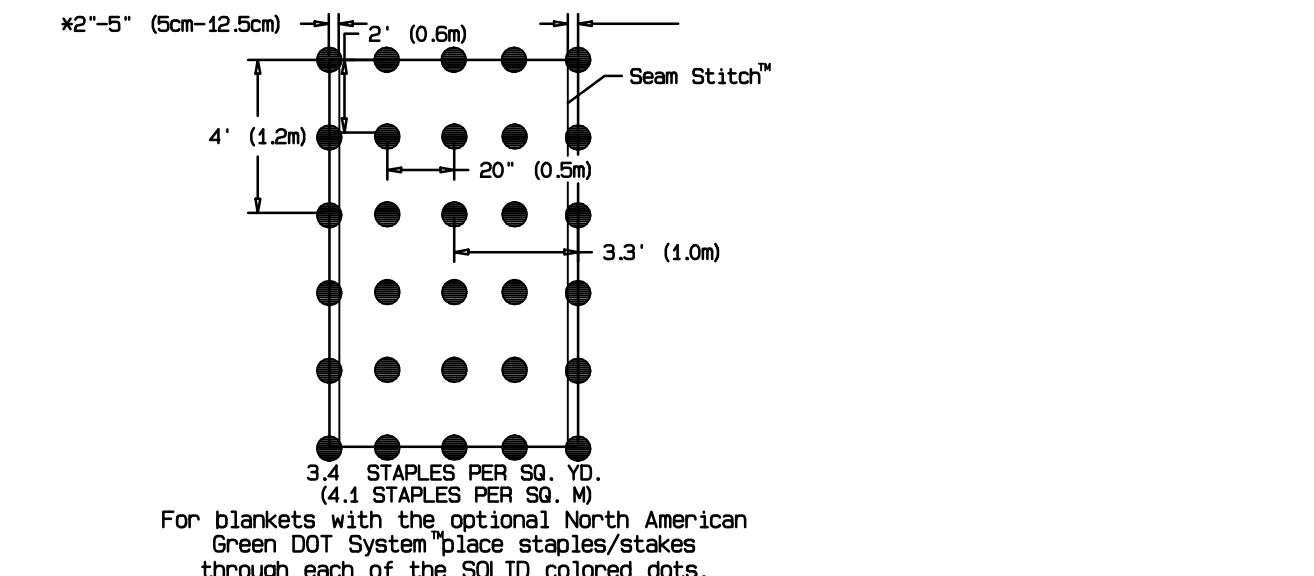

STAPLE PATTERN (D) DETAIL (USE WITH NAG S-75 LINING)

SOIL EROSION AND SEDIMENT CONTROL NOTES AND DETAILS

**CONSTRUCTION PLANS
FOR
EAST BLACKBERRY STREET
IMPROVEMENTS PLAN**

LOCATED IN
 JONESTOWN BOROUGH, LEBANON COUNTY, PENNSYLVANIA
 OWNER
 BOROUGH OF JONESTOWN
 295 S. MILL ST. PO BOX 446
 JONESTOWN, PA 17038
 (717) 861-5414

LIGHT-HEIGEL AND ASSOCIATES, INC.
 ENGINEERS AND SURVEYORS
 430 EAST MAIN STREET, PALMYRA, PA. 17078
 (717) 838-1351 FAX (717) 838-3820 1-800-257-2190 www.light-heigel.com

LANCASTER, PA	REGIONAL OFFICES HUNTSVILLE, AL	SCHUYLKILL HAVEN, PA
WEST CHESTER, PA	LEWISBURG, PA	

DATE: 02/03/2022
 SCALE: N/A
 COMP'D BY: SML

CHECKED BY: LL
 DRAWN BY: SML
 FIELD: LL

DWS. NO.: PA00-0091
 MAPCHECK: N/A
 SHEET: 4 OF 4



SECTION 01570

TRAFFIC REGULATION

PART 1 GENERAL

1.1 SECTION INCLUDES

- A. Construction parking controls.
- B. Flag persons.
- C. Traffic signs and signals
- D. Removal.

PART 2 PRODUCTS

2.1 SIGNS, SIGNALS, AND DEVICES

- A. Post Mounted and Wall Mounted Traffic Control and Informational Signs
- B. Traffic Control Signals: As required or directed.
- C. Traffic Cones and Drums, Flares and Lights: As required or directed.
- D. Flagperson Equipment: As required or directed.

PART 3 EXECUTION

3.1 CONSTRUCTION PARKING CONTROL

- A. Control vehicular parking to prevent interference with public traffic and parking, access by emergency vehicles, and Owner's operations.
- B. Monitor parking of construction personnel's vehicles. Maintain vehicular access to and through parking areas.
- C. Prevent parking on or adjacent to access roads or in non- designated areas.

3.2 FLAG PERSONS

- A. Provide trained and equipped flag persons to regulate traffic when construction operations or traffic encroach on public traffic lanes.

3.3 TRAFFIC SIGNS AND SIGNALS

- A. At approaches to site and on site, install at crossroads, detours, parking areas, and elsewhere as needed to direct construction and affected public traffic.
- B. Install and operate traffic control signals to direct and maintain orderly flow of traffic in areas under Contractor's control, and areas affected by Contractor's operations.
- C. Relocate as Work progresses, to maintain effective traffic control.

3.4 REMOVAL

- A. Remove equipment and devices at Substantial Completion.
- B. Repair damage caused by installation.

**** END OF SECTION 01570 ****

SECTION 02211

ROUGH GRADING

PART 1 GENERAL

1.1 SECTION INCLUDES

- A. Removal of topsoil and subsoil.
- B. Cutting and grading the site for construction.

PART 2 EXECUTION

2.1 EXAMINATION

- C. Verify that survey bench mark and intended elevations for the Work are as indicated.

2.2 PREPARATION

- A. Identify required lines, levels, contours, and datum.
- B. Stake and flag locations of known utilities.
- C. Locate, identify, and protect utilities that remain, from damage.
- D. Protect above and below grade utilities that remain.
- E. Protect plant life, lawns, and other features remaining as a portion of final landscaping.
- F. Protect bench marks, existing structures, fences, sidewalks, paving, and curbs from excavating equipment and vehicular traffic.

2.3 SUBSOIL EXCAVATION

- A. Excavate subsoil from areas to be further excavated, re-landscaped, or re-graded.
- B. Do not excavate wet subsoil.
- C. When excavating through roots, perform work by hand and cut roots with sharp axe.
- D. Stockpile in area designated on site and protect from erosion. Remove from site, subsoil not being reused.
- E. Stability: Replace damaged or displaced subsoil to same requirements as for specified fill.

2.4 FILLING

- A. Fill areas to contours and elevations with unfrozen materials.
- B. Place fill material on continuous layers and compact in accordance with the schedule at end of this section.
- C. Maintain optimum moisture content of fill materials to attain required compaction density.
- D. Slope grade away from building minimum unless noted otherwise.
- E. Make grade changes gradual. Blend slope into level areas.
- F. Remove surplus fill materials from site.

** END OF SECTION 02211 **

SECTION 02222

EXCAVATING

PART 1 GENERAL

1.1 SECTION INCLUDES

- A. Excavating curb and sidewalk accessible ramps.

1.2 RELATED SECTIONS

- A. Section 01400- Quality Control: Inspection of bearing surfaces.
- B. Section 01500 - Construction Facilities and Temporary Controls: Dewatering of excavations and water control.
- C. Section 02211 - Rough Grading: Topsoil and subsoil removal from site surface.
- D. Section 02223 - Backfilling.
- E. Section 02225 - Trenching: Excavating for utility trenches.
- F. Section 02229 - Rock removal: Removal of rock during excavating.
- G. Section 02655 - Cathodic Protection - Passive.
- H. Section 02667 - Site Water Lines.
- I. Section 02687 - Site Gas Lines.

1.3 FIELD MEASUREMENTS

- A. Verify that survey bench mark and intended elevations for the Work are as indicated.

PART 2 EXECUTION

2.1 PREPARATION

- A. Identify required lines, levels, contours, and datum locations.
- B. Locate, identify, and protect utilities that remain from damage.
- C. Protect plant life, lawns, and other features remaining as a portion of final landscaping.

-
- D. Protect bench marks, survey control points, existing structures, and curbs from excavating equipment and vehicular traffic.

2.2 EXCAVATING

- A. Underpin adjacent structures which may be damaged by excavating work.
- B. Excavate subsoil to accommodate building foundations, slabs-on-grade, paving and site structures, and construction operations.
- C. Compact disturbed load bearing soil in direct contact with foundations to original bearing capacity; perform compaction in accordance with Section 02223 and 02225.
- D. Slope banks with machine to angle of repose or less until shored.
- E. Do not interfere with 45 degree bearing splay of foundations.
- F. Grade top perimeter of excavating to prevent surface water from draining into excavation.
- G. Hand trim excavation. Remove loose matter.
- H. Remove lumped subsoil, boulders, and rock up to 1/3 cu. yd. measured by volume. Larger material will be removed under Section 02209.
- I. Notify Architect/Engineer of unexpected subsurface conditions and discontinue affected Work in area until notified to resume work.
- J. Remove excavated material from site.

2.3 FIELD CONTROL

- A. Prevent displacement or loose soil from falling into excavation; maintain soil stability.
- B. Protect bottom of excavations and soil adjacent to and beneath foundation from freezing.

** END OF SECTION 02222 **

SECTION 02370
EROSION AND SEDIMENT POLLUTION CONTROL

PART 1 – GENERAL

1.1 SCOPE OF WORK

- A. Under this Section of Specifications the Contractor shall provide all labor, tools, materials, and equipment required to perform all erosion and sediment pollution controls.

1.2 RELATED WORK SPECIFIED ELSEWHERE

- A. Site Clearing – See Section 02110.

1.3 GENERAL REQUIREMENTS

- A. The Contractor shall, prior to submitting his bid, visit the site, inform himself of the conditions and make his own estimates of the facilities and difficulties attending the execution of the work.
- B. All earthwork shall be coordinated with other trades and phased so as to accomplish earthwork in a manner that will prevent prolonged periods of open, bare earth without a suitable vegetation cover. This must be accomplished in order to eliminate soil and sediment runoff.
- C. Temporary grass seed cover shall be provided on all topsoil stockpiles and other areas of stockpiled excavated material to prevent soil erosion and rapid runoff during the construction period. Prolonged periods of open, bare earth without grass cover will not be permitted.
- D. The Contractor shall obtain and pay for all permits, tests, inspections, etc. required by agencies that have jurisdiction over the project. All work shall be executed and inspected in accordance with all local, state, and federal codes, rules, ordinances, or regulations pertaining to the particular type of work involved. Should any changes be required to conform to such ordinances, notify the Engineer at the time of submitting the bid. After entering into the Contract, the Contractor shall be held responsible for the completion of all work necessary for a complete and approved installation without extra expense to the Owner. This Contractor shall prepare any supplementary detailed diagrams or drawings which may be required by any local or state authority at no additional cost to the Owner.

1.4 JOB CONDITIONS FOR PERMANENT SEEDING

- A. Begin seeding after preceding related portions of the Work are accepted by the Engineer. Ensure that topsoil placement and finished grading have been completed prior to installation.

- B. Remove any clay lumps, stones, roots, vegetation, stumps, or any other extraneous debris and leave soil surfaces smoothly graded to ensure positive drainage away from structures and planted areas.
- C. Environmental Requirements: Regular seeding season is March 1 to May 15 and August 1 to October 15. No seeding shall be done on frozen ground, or when the temperature is 32EF or lower or 90EF or higher.

1.5 QUALITY ASSURANCE

- A. All erosion and sediment pollution control shall be accomplished in accordance with the Specifications and Drawings, and in strict accordance with the approved "Erosion and Sediment Pollution Control Plan" and the Chapter 106 permits for the site. All directives issued by any government agency having authority over this project shall be closely adhered to during the project. Any fines and associated costs resulting from the Contractors failure to provide adequate protection against soil erosion and sediment pollution shall be borne by the Contractor.

PART 2 – PRODUCTS

2.1 MATERIALS

- A. Aggregate for stabilized construction entrance shall consist of Type C AASHTO No. 1 aggregate conforming to PennDOT 408 Specifications, as amended, Section 703.
- B. Rip Rap material shall be clean Type C- Rock, to meet all requirements of PennDOT. Sizes as shown on the Drawings.
- C. Geotextile shall consist of woven or non-woven fabric, a long chain polymeric filaments or yarns; such as polyethylene, polyamide, etc. formed into a stable network. Fabric shall be inert to commonly encountered construction chemicals and substances.
 - 1. Ship and store geotextile fabric in accordance with manufacturer's recommendations.
 - 2. The geotextile fabric for the stabilized construction entrance shall be Class 4.
 - 3. The geotextile fabric for rock lining shall be Class 2.
- D. Wood stakes shall be solid, rough-sawed, red or white cedar or hard wood measuring 2"x2", length may be as required, with one pointed end.
- E. Reinforcement bars shall be ASTM A15 (S1) grade 60 deformed.
- F. Filter fabric shall be a continuous previous sheet of propylene, nylon, ethylene, or polyester. The filter fabric shall be certified by the manufacturer as conforming to the following requirements:

1. Filtering efficiency according to test of ETM-51-75% efficiency.
2. Tensile strength at 20% elongation Test VTM-52 50 lbs. Per linear inch minimum extra strength, 30 lbs. per linear inch standard stream.
3. Flow rate according to Test VTM-51-0.3 gallons per square foot per minute minimum.

The requirements for the tensile strength shall be reduce by 50% after 60 months of installation.

The filter fabric shall contain ultra-violet ray inhibitors and stabilizers to provide a minimum of six months of expected usable construction life at a temperature range of 0 – 120 degrees Fahrenheit.

- G. Stakes for filter barriers shall consist of nominal 1"x2" hardwood or equivalent steel reinforcing bars with a minimum height of three feet.
- H. Wire fence reinforcement for silt fences using standard strength filter cloth shall be a minimum of 42" in height and a minimum of 14 gauge, and shall have a maximum mesh spacing of 6".
- I. Agricultural liming materials shall consist of products containing calcium and magnesium compounds capable of neutralizing soil acidity and not less than 80% of total carbonates.
- J. Fertilizers shall be commercially obtainable chemical fertilizer of the uniform composition, free flowing and in conformity with applicable state fertilizer laws.
- K. Temporary grass seed.
- L. Permanent Seed shall be new crop grass, furnished in sealed packages with proof of correct mixture evidenced on bag, age of seed indicated, in compliance with applicable regulations noted as required. Seeds and mixtures shall consist of annual rye grass, 100% mix by weight, 88% purity, 90% germination, with a maximum percent of weed seed of 0.15.
- L. Straw mulch shall be salt marsh straw or straw free of fertile weeds and weed seeds. Fumigation of straw with an approved soil fumigant by a certified applicator is permitted. The use of hay is not permitted.
- M. Rock lining: Rock shall be in accordance with PennDOT Publication 408, Section 850.2.

PART 3 – EXECUTION

3.1 EXISTING STRUCTURES AND FACILITIES

- A. Existing structures and facilities shall be protected from erosion and sediment pollution

- B. Items to be protected from sediment deposits shall include, but are not limited to, all downstream property, natural waterways, streams, catch basins, drainage ditches, roads, gutters, and natural buffer zones.
- C. Control measures such as erection of silt fences, barriers, check dams, or other structures shall begin prior to any land disturbing activity. Additional measures shall be constructed as required during construction at no additional cost.
- D. Rip rap shall be installed to protect the stream bottom from future scour.

3.2 PERMANENT SEED INSTALLATION

- A. Fertilizer shall be. Applied at a rate of 35 lbs. per 1,000 s.f. Cultivate topsoil to a minimum depth of 3" and rake after amendments have been added.
- B. Ensure that the finished seedbed is graded as per Section 02300 – Earthwork.
- C. The grass mixture shall be applied at a rate of 21 lbs per 1,000 sf. for all lawn areas.
- D. The grass mixture shall be sown in uniformly on the prepared areas by hydraulic placement, broadcasting, or hand seeding methods. Periodically perform a check on the rate and uniformity of application, as directed.
- E. After seed has been spread, compact seed beds with a culti-packer, roller, or other similar equipment.
- F. Following compaction, apply a 1/2" layer of straw to hasten germination. The straw mulch shall be anchored by either a mulch tiller, chemical mulch binder, twine, or netting. Asphalt emulsion shall not be used.

3.3 STRAW MULCH INSTALLATION

- A. Verify that final grading and related preceding portions of the Work have been completed.
- B. Topsoil shall not be used for lawn operations while in a frozen or muddy condition.

3.4 PERMANENT STABILIZATION

- A. Protected areas shall be stabilized permanently prior to removal of temporary protective devices.

- B. After final establishment of permanent stabilization, temporary sedimentation and erosion control measures shall be removed and accumulated sediments, if any, shall be removed as required hereinbefore.
- C. Rock lining shall be placed in accordance with PennDOT Publication 408, Section 850.3.

3.5 MAINTENANCE

- A. All erosion and sediment pollution control measures shall be inspected periodically, especially after periods of rainfall to insure the devices are still in place and operating effectively.
- B. If, in fact, control measures are disturbed or inoperable the control measures shall be either cleaned, reset or replaced to the satisfaction of the Owner, at no additional cost to Owner.
- C. All facilities installed shall be maintained continuously during construction and until disturbed areas are stabilized.
- D. Accumulated sediments shall be removed when control device has silted to one-half the original capacity.

3.6 CLEAN UP

- A. Upon completion of the work all surplus materials, debris, tools and equipment shall be removed from the site.

** END OF SECTION 02370 **

SECTION 02923
LANDSCAPE GRADING

PART 1 GENERAL

1.1 SECTION INCLUDES

- A. Final grade topsoil for finish landscaping.

PART 2 PRODUCTS

2.1 MATERIAL

- A. Topsoil: Clean topsoil free of organic material, weeds, rocks, and foreign material.

PART 3 EXECUTION

3.1 EXAMINATION

- A. Verify building and trench backfilling have been inspected.
- B. Verify substrate base has been contoured and compacted.

3.2 SUBSTRATE PREPARATION

- A. Eliminate uneven areas and low spots.
- B. Remove debris, roots, branches, stones, in excess of 1 inch in size. Remove subsoil contaminated with petroleum products.
- C. Scarify surface to depth of 3 inches where topsoil is scheduled. Scarify in areas where equipment used for hauling and spreading topsoil has compacted subsoil.

3.3 PLACING TOPSOIL

- A. Place topsoil in areas where seeding and planting is required. To a nominal depth of 6 inches. Place topsoil during dry weather.
- B. Fine grade topsoil to eliminate rough or low areas. Maintain profiles and contour of subgrade.
- C. Remove roots, weeds, rocks, and foreign material while spreading.
- D. Manually spread topsoil close to plant life to prevent damage.
- E. Lightly compact placed topsoil.

F. Remove surplus subsoil and topsoil from site.

G. Leave stockpile area and site clean and raked, ready to receive landscaping.

3.4 PROTECTION

G. Protect landscaping and other features remaining as final work.

H. Protect existing structures, fences, sidewalks, utilities, paving, and curbs.

3.5 SCHEDULES

A. Compacted topsoil thickness at the following areas:

1. Seeded Grass: 6 inches.

** END OF SECTION 02923 **

SECTION 02936

SEEDING

PART 1 GENERAL

1.1 SECTION INCLUDES

- A. Preparation of subsoil.
- B. Placing topsoil.
- C. Seeding, Hydroseeding, mulching.
- D. Maintenance.

1.2 UNIT PRICE - MEASUREMENT AND PAYMENT

- A. Grassed Areas: By the square yard. Includes placing topsoil, seeding, and mulching

1.3 DEFINITIONS

- A. Weeds: Include Dandelion, Jimsonweed, Quackgrass, Horsetail, Morning Glory, Rush Grass, Mustard, Lambsquarter, Chickweed, Cress, Crabgrass, Canadian Thistle, Nutgrass, Poison Oak, Blackberry, Tansy Ragwort, Bermuda Grass, Johnson Grass, Poison Ivy, Nut Sedge, Nimble Will, Bindweed, Bent Grass, Wild Garlic, Perennial Sorrel, and Brome Grass.

1.4 QUALITY ASSURANCE

- A. Provide seed mixture in containers showing percentage of seed mix, year of production, net weight, date of packaging, and location of packaging.

1.5 DELIVERY, STORAGE, AND PROTECTION

- B. Deliver grass seed mixture in sealed containers. Seed in damaged packaging is not acceptable.
- C. Deliver fertilizer in waterproof bags showing weight, chemical analysis, and name of manufacturer.

PART 2 PRODUCTS

2.1 SOIL MATERIALS

- A. Topsoil: Fertile, agricultural soil, typical for locality, capable of sustaining vigorous plant growth, taken from drained site; free of subsoil, clay or impurities, plants, weeds and roots
- B. Topsoil excavated from site and free of weeds may also be used with permission of project

engineering representative

2.2 ACCESSORIES

- A. Mulching Material: Oat or wheat straw, free from weeds, foreign matter detrimental to plant life, and dry. Hay or chopped cornstalks are acceptable.

PART 3 EXECUTION

3.1 EXAMINATION

- A. Verify that prepared soil base is ready to receive the work of this section.

3.2 PREPARATION OF SUBSOIL

- A. Prepare subsoil to eliminate uneven areas and low spots. Maintain lines, levels, profiles and contours. Make changes in grade gradual. Blend slopes into level areas.
- B. Remove foreign materials, weeds and undesirable plants and their roots. Remove contaminated subsoil.
- C. Scarify subsoil to a depth of 3 inches where topsoil is to be placed. Repeat cultivation in areas where equipment, used for hauling and spreading topsoil, has compacted sub-soil.

3.3 PLACING TOPSOIL

- A. Spread topsoil to a minimum depth of 6 inches over area to be seeded. Rake until smooth.
- B. Place topsoil during dry weather and on dry unfrozen subgrade.
- C. Remove vegetable matter and foreign non-organic material from topsoil while spreading.
- D. Grade topsoil to eliminate rough, low or soft areas, and to ensure positive drainage.
- E. Install edging at periphery of seeded areas in straight lines to consistent depth.

3.4 SEEDING

- A. Apply seed per manufactures specifications evenly in two intersecting directions. Rake in lightly.
- B. Do not seed areas in excess of that which can be mulched on same day.
- C. Do not sow immediately following rain, when ground is too dry, or during windy periods.
- D. Immediately following seeding apply mulch to a thickness of 1/8 inches. Maintain clear of shrubs and trees.

- E. Apply water with a fine spray immediately after each area has been mulched. Saturate soil.

3.5 HYDROSEEDING

- A. Apply seeded slurry with a hydraulic seeder per manufactures specifications evenly in two intersecting directions.
- B. Do not hydro-seed area in excess of that which can be mulched on same day.
- C. Immediately following seeding, apply mulch. Maintain clear of shrubs and trees.
- D. Apply water with a fine spray immediately after each area has been mulched.

** END OF SECTION 02936 **

Highway Occupancy Permit

Permit No.: **08108367**

Name and Address of Permittee: Jonestown Borough 295 South Mill Street P.O. Box 446 Jonestown, PA 17038	County: Lebanon	Issue Date: 3/24/2022
	County Contact No.: (717) 272-6637	Expiration Date: 3/24/2023
	Issuing District Office: 8-0	Application No.: 266372
	District Contact No.: (717) 705-0925	Account No.:
	Municipalities: Jonestown Borough	Permit Fee: \$ 0.00

Immediately upon completion of the work Permittee shall notify the permit office where application was made. Subject to all the conditions, agreements, restrictions, and regulations prescribed by the Pennsylvania Department of Transportation, (see in particular 67 Pa. Code, Chapter 212, 441 and 459 and State Highway Law, 36 P.S. Section 670 - 411, 420 and 421) and subject to the plans, special conditions, or restrictions herein set forth or attached hereto. This permit shall be located at the work site and shall be available for inspection by any police officer or Department representative.

Location and Description of Work		Permit No.: 08108367
1 of 1	State Route #: 1003 Segment(s): From 0130 To 0130 Offset(s): From 0579 To 0610	102: REPLACE CURB RAMP

Permit Conditions		Permit No.: 08108367
1 of 27	A CERTIFICATE OF INSURANCE SHALL BE SUBMITTED TO THE DEPT. BY THE PERMITTEE OR ITS CONTRACTOR 30 DAYS PRIOR TO START OF WORK.	
2 of 27	<p>FOLLOWING CONSTRUCTION OF EACH CURB RAMP, COMPLETE AND SUBMIT TO THE DEPARTMENT CURB RAMP INSPECTION FORM (CS-4401). CHECK ALL SLOPES WITH A FOUR FOOT SMART LEVEL FOR COMPLIANCE. CURB RAMPS THAT ARE FOUND TO BE NON-COMPLIANT AS A RESULT OF COMPLETING THE INSPECTION FORM WILL BE RECONSTRUCTED UNLESS THE CURB RAMP DETAIL IN QUESTION HAD BEEN AUTHORIZED TO BE CONSTRUCTED THROUGH THE USE OF AN APPROVED TECHNICALLY INFEASIBLE FORM.</p> <p>THE DEPARTMENT WILL NOT ACCEPT ANY NEWLY CONSTRUCTED CURB RAMP THAT DOES NOT FULLY COMPLY WITH THE STANDARD DRAWINGS RC 67M REQUIREMENTS UNLESS THE CURB RAMP DETAIL IN QUESTION HAD BEEN AUTHORIZED TO BE CONSTRUCTED THOROUGH THE USE OF AN APPROVED TECHNICALLY INFEASIBLE FORM (TIF). A TIF WILL NOT BE APPROVED AFTER A RAMP HAS BEEN CONSTRUCTED.</p> <p>THE CURB RAMP INSPECTION FORM (CS-4401) MUST BE FULLY COMPLETED INCLUDING THE NAME OF THE PERSON WHO FIELD VIEWED THE SITE (DESIGNER), THE RAMP LOCATION IN THE DIAGRAM, PHOTOS AND ADDITIONAL TABS TO INCLUDE FURTHER JUSTIFICATION/EXPLANATION FOR THE PROPOSED DESIGN. PLEASE MAKE SURE THAT ALL APPROPRIATE CELLS ARE COMPLETED AND INCLUDE PHOTOS DEPICTING THE PROPOSED RAMP LOCATION FROM DIFFERENT ANGLES. THE PHOTOS SHOULD BE CLOSE ENOUGH THAT DETAILS FOR DESIGN CAN BE SEEN AND EVALUATED.</p>	
3 of 27	IT IS THE PERMITTEES RESPONSIBILITY TO PROVIDE NECESSARY EQUIPMENT FOR TESTING OF MATERIALS DELIVERED ON SITE INCLUDING CERTIFIED TECHNICIANS.	
4 of 27	PERMITTEE IS RESPONSIBLE TO HAVE APPROVED FLAGGERS DURING WORK HOURS TO ENSURE SAFETY WHEN CONSTRUCTION EQUIPMENT AND VEHICLES ARE ENTERING AND EXITING THE CONSTRUCTION ENTRANCE. PROPER SIGNAGE MAY BE REQUIRED, CHECK WITH THE COUNTY SUPERVISOR PRIOR TO INSTALLING THE DRIVEWAY.	

Highway Occupancy Permit

Permit No.: **08108367**

Permit Conditions		Permit No.: 08108367
5 of 27	PERMITTEES CONTRACTOR MUST PROVIDE PROPOSED WORK SCHEDULE 3 DAYS BEFORE START OF WORK. ALSO, PROVIDE AN EMERGENCY PHONE CONTACT NUMBER TO THE DEPARTMENT.	
6 of 27	CONTACT COUNTY PERMIT INSPECTOR SUPERVISOR, LUCAS FOWLER, AT LEAST 3 WORKDAYS PRIOR TO THE START OF WORK AT 717-783-0156 x315 OR LUFOWLER@PA.GOV.	
7 of 27	THIS PERMIT AUTHORIZES WORK ONLY IN DEPARTMENT HIGHWAY RIGHT OF WAY.	
8 of 27	2A COARSE AGGREGATE BACKFILL MATERIAL IS REQUIRED UNDER 67 PA CODE, SECTION 459.8 (g)(2) AND SECTION 703.2 OF PUBLICATION 408.	
9 of 27	DEPARTMENT MUST BE NOTIFIED IN WRITING UPON COMPLETION OF WORK.	
10 of 27	TEMPORARY PAVEMENT RESTORATION AUTHORIZED CONSISTENT WITH SECTION 459.8(K), FOR NO MORE THAN 30 DAYS.	
11 of 27	COMPLETE PERMANENT PAVEMENT RESTORATION IN ACCORDANCE WITH SECTION 459.8, PRIOR TO EXPIRATION DATE. EACH PATCH MUST BE PAINTED IN ACCORDANCE WITH SECTION 459.8(L).	
12 of 27	THE PERMITTEE IS REQUIRED TO USE HOT MIX OR WARM MIX MATERIAL FOR TEMPORARY RESTORATION. COLD MIX WILL BE PERMITTED AT THE DISCRETION OF THE DEPARTMENT. PERMITTEE MUST MAINTAIN A SMOOTH PAVEMENT SURFACE SUITABLE FOR DRIVING FOR THE DURATION OF THE TEMPORARY PAVEMENT.	
13 of 27	BACKFILL COMPACTION TESTING IS REQUIRED A MINIMUM ONE TEST PER LIFT DAILY. FOR OPENINGS LESS THAN OR EQUAL TO 500 TOTAL FEET IN PAVEMENT, SHOULDER OR SIDEWALK, THE PERMITTEE MAY CHOOSE THE COMPACTION TEST METHOD, PROVIDED THE TEST METHOD IS PERFORMED CONSISTENT WITH DEPARTMENT PUBLICATIONS, AND ON THE CONDITION THAT THE PERMITTEE PROVIDE THE COMPLETED CS-6 (PIPE INSTALLATION INSPECTION FORM) AND ACCOMPANYING TR-478 AND/OR TR-4276 FORMS WITHIN TWO WEEKS OF THE COMPLETION OF THE WORK REPRESENTED ON THE FORM. PENNDOT WILL NOT CLOSE-OUT THE PERMIT PRIOR TO RECEIVING THE COMPLETED FORMS.	
14 of 27	CURB MUST BE INSTALLED IN ACCORDANCE WITH PENNDOT ROADWAY STANDARDS RC-64M AND RC-67M.	
15 of 27	SHOULDERS MUST BE RESTORED IN ACCORDANCE WITH APPROPRIATE SECTION OF PUB. 408 AND ROADWAY CONSTRUCTION STANDARDS RC-25M.	
16 of 27	PERMITTEE MUST MAINTAIN EXISTING SHOULDER DURING CONSTRUCTION.	
17 of 27	SURFACE DRAINAGE MAY NOT BE DIRECTED ONTO STATE HIGHWAY RIGHT OF WAY.	
18 of 27	ACCESS SIGNING AND PAVEMENT MARKINGS DISTURBED BY THE PERMITTED WORK MUST BE REPLACED IN KIND.	
19 of 27	SIDEWALK CONSTRUCTION OR REPLACEMENT SHALL PROVIDE ACCOMMODATIONS FOR PERSONS WITH DISABILITIES CONSISTENT WITH ADA AND PENNDOT STANDARDS.	
20 of 27	POLES AND ABOVEGROUND FACILITIES MUST BE PLACED IN ACCORDANCE WITH THE AMERICANS WITH DISABILITIES ACT (ADA).	
21 of 27	ALL DISTURBED AREAS OUTSIDE THE PAVEMENT OR SHOULDER SHALL BE RESTORED TO A CONDITION AT LEAST EQUAL TO THAT WHICH EXISTED BEFORE THE START OF WORK.	

Highway Occupancy Permit

Permit No.: **08108367**

Permit Conditions		Permit No.: 08108367
22 of 27	MINIMUM WORK ZONE TRAFFIC CONTROL TO BE IN ACCORDANCE WITH PUB. 213. SEE PUB 212 FOR ADDITIONAL DETAILS.	
23 of 27	NO LANES MAY BE RESTRICTED BETWEEN THE HOURS OF 6:00 AM TO 9:00 AM OR BETWEEN THE HOURS OF 3:00 PM TO 6:00 PM.	
24 of 27	WORK WITHIN THE STATE RIGHT OF WAY WILL NOT BE PERMITTED DURING ALL STATE AND NATIONAL HOLIDAYS. CONTRACTORS ARE REQUIRED TO BE OFF THE ROADWAY BY NOON ON THE BUSINESS DAY PRIOR TO THE HOLIDAY. EQUIPMENT AND/OR MATERIALS ARE NOT PERMITTED WITHIN THE DEPARTMENT RIGHT OF WAY OR THE CLEAR ZONE DURING THIS TIME. WORK MAY RESUME AFTER THE HOLIDAY (NORMAL WORKING HOURS) UNLESS DIRECTED DIFFERENTLY BY A DEPARTMNET REPRESENTATIVE. CONTRACTOR MUST PROVIDE A WORK SCHEDULE TO THE COUNTY INSPECTOR IN CHARGE FOR ANY WORK DONE BETWEEN THANKSGIVING AND NEW YEARS DAY FOR APPROVAL.	
25 of 27	PERMITTEE IS RESPONSIBLE FOR ENSURING THAT MUD, SILT AND OTHER DEBRIS IS REMOVED FROM VEHICLES AND TIRES (BY POWER WASH, ETC.) BEFORE ENTERING ONTO THE HIGHWAY.	
26 of 27	PERMITTEES CONTRACTOR MUST INFORM JONESTOWN BOROUGH FIVE WORKING DAYS PRIOR TO THE START OF PERMITTED WORK.	
27 of 27	ALL WORK WITHIN THE STATE RIGHT OF WAY MUST FOLLOW SPECIFICATIONS AND STANDARDS OF PUBLICATIONS 408 AND 72M.	

<p>Acknowledgement of Completion</p> <p>Permit work has been completed:</p> <p>Date:</p> <p>By:</p>	<p>Yassmin Gramian, P.E.</p> <p>-----</p> <p>Secretary of Transportation</p> <p>Christopher J. Kufro, P.E.</p> <p>-----</p> <p>Acting District Executive</p>
--	---



HOP PLANS FOR THE BOROUGH OF JONESTOWN

LOCATED IN
BOROUGH OF JONESTOWN, LEBANON COUNTY, PENNSYLVANIA

JONESTOWN BOROUGH UTILITY LIST

FACILITY OWNER	CONSTRUCTION	DESIGN
COMCAST CABLE LEBANON	925 IRWIN RUN ROAD WEST MIFFLIN, PA 15122 1-800-242-1776	1233 CUMBERLAND STREET LEBANON, PA 17042 1-800-242-1776
FIRST ENERGY CORP	925 IRWIN RUN ROAD WEST MIFFLIN, PA 15122 1-800-242-1776	76 SOUTH MAIN STREET AKRON, OH 44308-1890 1-800-242-1776
JONESTOWN BOROUGH	925 IRWIN RUN ROAD WEST MIFFLIN, PA 15122 1-800-242-1776	295 SOUTH MILL STREET JONESTOWN, PA 17038 1-800-242-1776
LEBANON CITY AUTHORITY	925 IRWIN RUN ROAD WEST MIFFLIN, PA 15122 1-800-242-1776	2200 WEST CHESTNUT STREET LEBANON, PA 17042 1-800-242-1776
NORTHERN LEBANON COUNTY AUTHORITY	925 IRWIN RUN ROAD WEST MIFFLIN, PA 15122 1-800-242-1776	400 JONESTOWN ROAD P. O. BOX 431 JONESTOWN, PA 17038-0431 1-800-242-1776
VERIZON NORTH	925 IRWIN RUN ROAD WEST MIFFLIN, PA 15122 1-800-242-1776	2201 EAST 30TH STREET ERIE, PA 16510 1-800-424-1776

LIGHT-HEIGEL & ASSOCIATES, INC., HEREBY STATES THAT, PURSUANT TO THE PROVISIONS OF ACT NO. 121 OF OCTOBER 2008 OF THE PENNSYLVANIA GENERAL ASSEMBLY, IT HAS PERFORMED THE FOLLOWING IN PREPARING THESE DRAWINGS: REQUIRING EXCAVATION OR DEMOLITION WORK AT SITES WITHIN THE POLITICAL SUBDIVISION(S) SHOWN ON THE DRAWINGS:

(1) PURSUANT TO SECTION 4, CLAUSE (2) OF SAID ACT, LIGHT-HEIGEL & ASSOCIATES, INC. REQUESTED THE LINE AND FACILITY INFORMATION DESCRIBED BY SECTION 2, CLAUSE (4) FROM A ONE CALL SYSTEM NOT LESS THAN TEN (10) WORKING DAYS BEFORE FINAL DESIGN IS TO BE COMPLETED.

(2) PURSUANT TO SECTION 4, CLAUSE (3) OF SAID ACT, LIGHT-HEIGEL & ASSOCIATES, INC. SHOWN UPON THE DRAWING(S) THE POSITION AND TYPE OF EACH FACILITY OWNER'S LINE, DERIVED PURSUANT TO THE REQUEST MADE AS REQUIRED BY SECTION 4, CLAUSE (2), AND THE NAME OF THE FACILITY OWNER, AND THE FACILITY OWNER'S DESIGNATED OFFICE ADDRESS AND THE TELEPHONE NUMBER AS SHOWN ON THE LIST REFERRED TO IN SECTION 3.

(3) PURSUANT TO SECTION 4, CLAUSE (4) OF SAID ACT, LIGHT-HEIGEL & ASSOCIATES, INC. MADE A REASONABLE EFFORT TO PREPARE THE CONSTRUCTION DRAWING(S) TO AVOID DAMAGE TO AND MINIMIZE INTERFERENCE WITH A FACILITY OWNER'S FACILITIES IN THE CONSTRUCTION AREA BY MAINTAINING THE CLEARANCE AS PROVIDED FOR IN THE APPLICABLE EASEMENT AN EIGHTEEN-INCH CLEARANCE OF THE FACILITY OWNER'S FACILITIES IF NO EASEMENT RESTRICTION EXISTS.

(4) PURSUANT TO SECTION 4, CLAUSE (5) OF SAID ACT, LIGHT-HEIGEL & ASSOCIATES, INC., SHALL BE DEEMED TO HAVE MET THE OBLIGATIONS OF CLAUSE (2) BY CALLING A ONE CALL SYSTEM AND SHOWING AS SHOWN ON THE DRAWING(S) THE ONE CALL NOTICE ON THE DRAWING(S) AND THE TOLL-FREE NUMBER OF THE ONE CALL SYSTEM. (JONESTOWN BOROUGH, LEBANON COUNTY - SERIAL # 2022080908 EXPIRES 06/07/2022)

AND LIGHT-HEIGEL & ASSOCIATES, INC. DOES NOT MAKE ANY REPRESENTATION, WARRANTY, ASSURANCE OR GUARANTEE THAT THE INFORMATION RECEIVED PURSUANT TO SAID REQUEST AND AS REFLECTED ON THESE DRAWINGS IS CORRECT OR ACCURATE BUT LIGHT-HEIGEL & ASSOCIATES, INC. IS REFLECTING SAID INFORMATION ON THESE DRAWINGS ONLY DUE TO THE REQUIREMENTS OF THE SAID ACT 121, OCTOBER 2008.

GENERAL NOTES:

- THIS PLAN IS NOT TO BE CONSTRUED AS AN ENVIRONMENTAL AUDIT/ASSESSMENT PLAN. THIS SURVEY MAKES NO WARRANTY OR GUARANTEE EITHER EXPRESSED OR DESCRIBED I.E., THE DETECTION OF SUBSURFACE CONTAMINANTS AS DEFINED IN D.E.P. TITLE 25-PA CODES 75, 101, 271, 273, 277, 279, 281 AND 285, AS AMENDED.
- THE INFORMATION SHOWN ON THESE DRAWINGS MAY HAVE ALREADY BEEN PROVIDED IN A DIGITAL DRAWING FORMAT. ONCE A DRAWING IS RELEASED FROM LIGHT-HEIGEL & ASSOCIATES, INC. IN A DIGITAL FORMAT, THERE IS NO CONTROL OVER THE MANIPULATION OR MISUSE OF THE DATA CONTAINED IN THAT FILE. THE VIEWER IS THEREFORE CAUTIONED TO COMPARE ANY SUBSEQUENT REPRODUCTIONS OR MANIPULATIONS OF THIS DATA WITH THE ORIGINAL HARD COPY SEALED PLAN PROVIDED BY LIGHT-HEIGEL & ASSOCIATES, INC. THE USER IS ALSO CAUTIONED THAT ANY USE OF THE DATA CONTAINED IN THE DIGITAL FILE THAT IS NOT SHOWN ON THE HARD COPY DRAWING SHALL BE AT THE RISK OF THE USER.
- ANY REVISIONS TO THIS PLAN AFTER THE DATE OF PLAN PREPARATION OR THE LATEST REVISION SHALL NOT BE THE RESPONSIBILITY OF LIGHT-HEIGEL AND ASSOCIATES, INC.
- THE SITE CONSTRUCTION SHALL BE IN COMPLIANCE WITH THE APPROVED PLANS.
- THESE PLANS ARE NOT TO BE CALLED FOR CONSTRUCTION PURPOSES.
- ALL DIMENSIONS SHALL BE VERIFIED ON SITE PRIOR TO THE START OF CONSTRUCTION. ANY AND ALL DISCREPANCIES SHALL BE REPORTED TO LIGHT-HEIGEL AND ASSOCIATES, INC. IN WRITING PRIOR TO CONSTRUCTION.
- ALL WORK SHALL COMPLY WITH FEDERAL, STATE AND LOCAL CODES INCLUDING MUNICIPAL REGULATIONS AS APPLICABLE.
- ALL CONSTRUCTION SHALL BE SUBJECT TO THE REQUIREMENTS OF THE PENNSYLVANIA UNIFORM CONSTRUCTION CODE, AS ADOPTED BY THE MUNICIPALITY.
- PENNSYLVANIA LAW REQUIRES 3 WORKING DAYS NOTICE FOR CONSTRUCTION PHASE. STOP-CALL BEFORE YOU DIG 1-800-242-1776.
- NOTHING SHALL BE PLACED, PLANTED OR SET WITHIN AN EASEMENT OR RIGHT-OF-WAY WHICH WOULD ADVERSELY AFFECT THE FUNCTION OF THE EASEMENT OR RIGHT-OF-WAY, OR CONFLICT WITH ANY CONDITIONS ASSOCIATED WITH SUCH EASEMENT OR RIGHT-OF-WAY.
- PER REQUIREMENTS OF CHAPTER 102 OF THE ADMINISTRATIVE CODES OF TITLE 25 (PENNSYLVANIA DEPARTMENT OF ENVIRONMENTAL PROTECTION RULES AND REGULATIONS), A COPY OF THE EROSION AND SEDIMENT POLLUTION CONTROL PLAN AND ITS ACCOMPANYING NARRATIVE MUST BE AVAILABLE ON SITE DURING CONSTRUCTION UNTIL THE SITE HAS BEEN PERMANENTLY STABILIZED.
- MATERIALS USED TO CONSTRUCT EMBANKMENTS FOR ANY PURPOSE, BACKFILL AROUND DRAINAGE STRUCTURES, OR UTILITY TRENCHES, OR ANY OTHER DEPRESSION REQUIRING FILL OR BACKFILL SHALL BE COMPACTED TO 95% OF MAXIMUM DENSITY AND WITHIN 80% OPTIMUM MOISTURE CONTENT AS DETERMINED BY THE MODIFIED PROCTOR COMPACTION TEST AS SET OUT IN ASTM D-1557. THE CONTRACTOR SHALL, PRIOR TO ANY OPERATIONS INVOLVING FILLING OR BACKFILLING, SUBMIT THE RESULTS OF THE PROCTOR TEST TOGETHER WITH A CERTIFICATION THAT THE SOIL TESTED IS REPRESENTATIVE OF THE MATERIALS TO BE USED ON THE PROJECT. TESTS SHALL BE CONDUCTED BY A LICENSED PROFESSIONAL ENGINEER.
- ALL MACADAM JOINTS AND WHERE CURBING AND MACADAM MEET IN AREAS OF WORK SHALL BE SAW-CUT AND SEALED WITH PG 64-22.
- ALL CONSTRUCTION OR MODIFICATION OF ALL STREETS SHALL COMPLY WITH CURRENT MUNICIPAL STANDARDS AS SET FORTH IN THEIR ORDINANCE AND SPECIFICATIONS BASED ON THE CONSTRUCTION STANDARDS OF PENNDOT PUBLICATION 408 AND PENNDOT PUBLICATION 72M "STANDARDS FOR ROADWAY CONSTRUCTION", RC-01M-100M, AS AMENDED.
- THE CONTRACTOR SHALL BE RESPONSIBLE FOR ALL TRAFFIC CONTROL, TRENCH BARRICAADING, COVERING, SHEETINGS AND SHORING, AS THE NEED ARISES.
- IT WILL BE THE CONTRACTOR'S RESPONSIBILITY TO ENSURE THAT THE GRADING PLAN IS IMPLEMENTED CORRECTLY, AND THAT PROPER DRAINAGE IS PROVIDED DURING CONSTRUCTION.
- ALL CURBS AND SIDEWALKS REQUIRING IMPROVEMENTS AS PART OF THIS PLAN AND OR CONSTRUCTION ACTIVITIES SHALL BE REPAIRED IN ACCORDANCE WITH ALL APPLICABLE PENNDOT STANDARDS AND REGULATIONS.
- EXISTING SURFACE UTILITIES ARE SHOWN IN ACCORDANCE WITH A FIELD SURVEY BY LIGHT-HEIGEL & ASSOCIATES, INC., SUBSURFACE UTILITIES SHOWN IN ACCORDANCE WITH VARIOUS SOURCES INCLUDING UTILITY FIELD MARKS, PLANS AND INFORMATION PROVIDED BY THE UTILITY PROVIDER AND ARE APPROXIMATE ONLY. THE CONTRACTOR WILL BE RESPONSIBLE FOR LOCATING ALL EXISTING UTILITIES WHICH MAY BE ENCOUNTERED DURING THE CONSTRUCTION OPERATION. HE SHALL, AT HIS OWN EXPENSE, ARRANGE WITH THE OWNERS OF SUCH UTILITIES FOR LOCATING THEM. THE CONTRACTOR SHALL BE HELD RESPONSIBLE FOR PROVIDING ADEQUATE PROTECTION AGAINST DAMAGE TO UTILITIES ENCOUNTERED DURING THE COURSE OF CONSTRUCTION AND SHALL BE RESPONSIBLE FOR REPAIR OF ANY UTILITIES DAMAGED DURING THE COURSE OF HIS CONSTRUCTION. THE CONTRACTOR SHALL BE RESPONSIBLE FOR CONTACTING THE PENNSYLVANIA ONE CALL SYSTEM INC. (1-800-242-1776), CONTACT THE PROJECT ENGINEER IMMEDIATELY IF A PROBLEM SHOULD ARISE. (717) 838-1351.
- PROTECTIVE FENCE SHALL BE PLACED AROUND ANY OPEN EXCAVATIONS AT THE END OF EACH WORK DAY.
- THE CONTRACTOR SHALL COORDINATE WORK WITH THE PUBLIC UTILITIES PRIOR TO ANY ACTIVITY THAT MAY AFFECT THE UTILITY FACILITIES.

GENERAL NOTES (CONT'D):

- THE CONTRACTOR IS RESPONSIBLE FOR IMPLEMENTING MEASURES TO PREVENT DAMAGE TO ALL EXISTING FEATURES (TO REMAIN) WITHIN THE PROJECT LIMITS.
- THE CONTRACTOR IS RESPONSIBLE FOR THE COORDINATION OF RELOCATING ANY CONFLICTING UTILITIES OR AS A RESULT OF THE IMPROVEMENTS. IF A CONFLICT ARISES WITH AN EXISTING UTILITY OR OTHER FEATURE THE CONTRACTOR SHALL CONTACT THE APPROPRIATE AGENCY TO PROVIDE A SUITABLE SOLUTION WHICH MAY INCLUDE CONCRETE ENCASUREMENT OR ANOTHER MEANS OF PROVIDING PROTECTION OF THE UTILITIES INVOLVED.
- CAUTION SHALL BE EXERCISED AT ALL TIMES FOR THE PROTECTION OF PERSONS AND PROPERTY IN ACCORDANCE WITH APPLICABLE LAWS AND CODES. COMPLIANCE WITH THE SAFETY PROVISIONS OF APPLICABLE LAWS AND BUILDING AND CONSTRUCTION CODES ARE THE CONTRACTOR'S RESPONSIBILITY.
- THE CONTRACTOR AND HIS SUBCONTRACTOR SHALL TAKE ALL PRECAUTIONS AND FURNISH AND MAINTAIN ALL GUARDS, BARRICADES, HANDRAILS, LIGHTS AND OTHER APPURTENANCES, ETC., FOR THE PROTECTION OF THE TRAVELING PUBLIC AND PROPERTY AT OR NEAR THE PROJECT.
- THE CONTRACTOR SHALL BE RESPONSIBLE FOR AND SHALL SEE THAT ALL EQUIPMENT, TOOLS, AND SUPPLIES ARE OPERATED OR HANDLED IN A SAFE MANNER AND SHALL COMPLY WITH ALL APPLICABLE REGULATIONS AND CODES.
- PROPERTY LINES AND ADDRESSES ARE SHOWN IN ACCORDANCE WITH COUNTY GIS MAPPING.
- ALL DISTURBED DRIVEWAYS AND OTHER APPLICABLE AREAS DISTURBED AS PART OF CONSTRUCTION SHALL BE REPAIRED IN ACCORDANCE WITH THE PLANS. ALL DISTURBED DRIVEWAYS SHALL BE REPLACED IN KIND AND DEPTH OF MATERIAL. THE CONTRACTOR SHALL ALSO PROVIDE POSITIVE DRAINAGE ON AREAS THAT HAVE BEEN DISTURBED.
- ALL SEEDING AND SOIL PER PENNDOT PUBLICATION 407/2011.
- THIS PROJECT IS SUBJECT TO INSPECTION BY THE PENNSYLVANIA DEPARTMENT OF TRANSPORTATION.
- SCHEDULE AND CONTROL ALL CONSTRUCTION TO MINIMIZE EROSION, PROVIDE AND MAINTAIN APPROVED EROSION AND SEDIMENTATION CONTROL MEASURES UNTIL ALL WORK IS COMPLETED.
- FURNISH AND INSTALL ALL TRAFFIC SIGNS AND PAVEMENT MARKINGS AS INDICATED.
- ALL EXISTING PAVEMENT MARKINGS WHICH ARE NO LONGER APPROPRIATE SHALL BE ERADICATED BY THE PERMITTEE. THE PERMITTEE SHALL PLACE ALL REQUIRED NEW OR DAMAGED BY CONSTRUCTION PAVEMENT MARKINGS.
- ALL NON-LONGITUDINAL PAVEMENT MARKINGS MUST BE HOT THERMOPLASTIC.
- PAVEMENT MARKING PLACEMENT ON THE STATE HIGHWAY SHALL BE IN ACCORDANCE WITH TC-8600, DATED JUNE 17, 2013.
- THE PERMITTEE IS RESPONSIBLE FOR THE MAINTENANCE OF ALL AUTHORIZED SIGNS AND PAVEMENT MARKINGS DURING THE PERIOD OF CONSTRUCTION.
- THE CONTRACTOR SHALL PROVIDE MATERIALS, AND CONSTRUCTION SHALL BE IN ACCORDANCE WITH THE SPECIFICATIONS, GUIDELINES AND REGULATIONS IN ACCORDANCE WITH THE APPLICABLE UTILITY IN WHICH THIS PLAN WAS PREPARED FOR.
- THE PROPERTY LINES ON THIS PLAN ARE SHOWN PER FIELD LOCATES.

PENNDOT HIGHWAY OCCUPANCY PERMIT NOTES:

- THE EXISTING SPEED LIMIT ON S.R. 1003 IS 35 M.P.H.
- THE RIGHT-OF-WAY IS FREE ACCESS.
- ALL WORK IN PA STATE HIGHWAY RIGHT-OF-WAY IS TO BE PERFORMED CONSISTENT WITH THE FOLLOWING: PENNDOT PUBLICATION 13M, DESIGN MANUAL PART 2 - HIGHWAY DESIGN; PENNDOT PUBLICATION 34, APPROVED AGGREGATE PRODUCERS (BULLETIN 14); PENNDOT PUBLICATION 35, APPROVED CONSTRUCTION MATERIALS (BULLETIN 15); PENNDOT PUBLICATION 41, PRODUCERS OF BITUMINOUS MATERIALS (BULLETIN 41); PENNDOT PUBLICATION 42, PRODUCERS OF READY-MIX CONCRETE (BULLETIN 42); PENNDOT PUBLICATION 46, TRAFFIC ENGINEERING MANUAL; PENNDOT PUBLICATION 72M, STANDARDS FOR ROADWAY CONSTRUCTION; PENNDOT PUBLICATION 111, PAVEMENT MARKINGS AND SIGNING STANDARDS; PENNDOT PUBLICATION 212, OFFICIAL TRAFFIC CONTROL DEVICES; PENNDOT PUBLICATION 213, TEMPORARY TRAFFIC CONTROL GUIDELINES; PENNDOT PUBLICATION 408, SPECIFICATIONS.
- DETAILS, OTHER THAN THOSE INDICATED, ARE ON THE FOLLOWING STANDARD DRAWINGS: PENNDOT PUBLICATION 72M, STANDARDS FOR ROADWAY CONSTRUCTION, APPLICABLE RC STANDARDS WITHIN PUBLICATION 72M INCLUDE, BUT ARE NOT LIMITED TO: RC20M, RC21M, RC25M, RC27M, RC28M, AND RC44M.
- PERMITTEE IS RESPONSIBLE FOR MAINTENANCE OF ALL AUTHORIZED STRUCTURES, FACILITIES AND DRAINAGE.
- PERMITTEE IS RESPONSIBLE FOR MAINTENANCE OF ALL AUTHORIZED SIGNS AND PAVEMENT MARKINGS.
- CONTACT PENNSYLVANIA ONE-CALL (1-800-242-1776) THREE WORKING DAYS BEFORE EXCAVATION OR DEMOLITION WORK.
- IF A TRAFFIC SIGNAL IS WITHIN 500 FEET OF THE SITE, CALL THE DISTRICT TRAFFIC ENGINEER AT LEAST 3 DAYS PRIOR TO THE START OF WORK.
- THIS PERMIT MAY BE RESTRICTED ON WORKING HOURS AND TIMES FOR HOLIDAYS, WEEKENDS, AND SPECIAL OR UNFORESEEN EVENTS AND WILL REQUIRE APPROVAL FROM THE COUNTY OFFICE PRIOR TO WORKING DURING THESE PERIODS.
- THE PERMITTEE'S CONTRACTOR SHALL SAWCUT AND REMOVE SHOULDER MATERIAL AS NECESSARY TO ENSURE THE PAVEMENT REPLACEMENT IS ADJACENT TO THE FULL-DEPTH PAVEMENT OF THE TRAVEL LANE.

PENNDOT HIGHWAY OCCUPANCY PERMIT NOTES (CONT'D):

- FINAL APPROVAL OF THE PROPOSED SAWCUT LOCATION WILL BE AT THE DISCRETION OF THE INSPECTOR-IN-CHARGE AND WILL BE CONFIRMED AT THE PRE-CONSTRUCTION MEETING. IF THE SAWCUT MUST BE LOCATED WITHIN A TRAVEL LANE, IT WILL BE NECESSARY TO MILL AND OVERLAY THE TRAVEL LANE TO PREVENT A JOINT IN A WHEEL PATH.
- THE PROPOSED PAVEMENT SECTION MUST BE AS INDICATED ON THE PLAN, OR MATCH THE EXISTING AS FOUND IN THE FIELD, WHICHEVER IS GREATER.
- PRIOR TO AN OVERLAY, BITUMINOUS OR CONCRETE BASE REPAIR OR JOINT REPLACEMENT MAY BE REQUIRED. REPAIR/REPLACEMENT WILL BE AT THE DISCRETION OF THE INSPECTOR-IN-CHARGE.
- ALL EXISTING PAVEMENT MARKINGS WHICH ARE NO LONGER APPROPRIATE SHALL BE ERADICATED BY THE PERMITTEE. THE PERMITTEE SHALL PLACE ALL REQUIRED NEW PAVEMENT MARKINGS.
- ALL PAVEMENT MARKINGS OTHER THAN LONGITUDINAL LINES TO BE HOT THERMOPLASTIC (PENNDOT PUBLICATION 111, TC-8600).
- MATCH EXISTING PAVEMENT MARKINGS AT THE LIMITS OF WORK.
- MATERIAL CERTIFICATION MUST BE PROVIDED, BY AN APPROVED MANUFACTURER LISTED IN THE DEPARTMENT'S PUBLICATION 35 (BULLETIN 15), FOR ALL MATERIALS AND STRUCTURES WITHIN PENNDOT RIGHT-OF-WAY.
- ALL SLOPE MEASUREMENTS WILL BE INSPECTED/VERIFIED WITH A 2-FOOT SMART LEVEL.
- THE PERMITTEE IS RESPONSIBLE FOR THE COORDINATION OF RELOCATING ANY CONFLICTING UTILITIES WHICH ARE A RESULT OF THESE IMPROVEMENTS.
- ALL UTILITY RELOCATION PERMITS TAKE PRECEDENCE OVER THE UTILITY RELOCATION POSITIONS SHOWN ON THE HOP PLANS.
- ALL CONCRETE CURB SHALL BE INSTALLED IN ACCORDANCE WITH THE PENNDOT STANDARD ROADWAY CONSTRUCTION DETAILS (PENNDOT PUBLICATION 72M, RC-64M).
- RIGHT-OF-WAY INFORMATION ON THIS PLAN IS SHOWN PER COMMONWEALTH OF PENNSYLVANIA DEPARTMENT OF HIGHWAYS DRAWINGS FOR CONSTRUCTION AND CONDEMNATION OF RIGHT-OF-WAY FOR ROUTE 3800S, SECTION 3, DISTRICT 8, LEBANON COUNTY.

PENNDOT MAINTENANCE AND PROTECTION OF TRAFFIC (MPT) NOTES:

- THIS WORK CONSISTS OF THE MAINTENANCE AND PROTECTION OF TRAFFIC AND THE PROTECTION OF THE PUBLIC WHEN APPROACHING AND DEPARTING THE CONSTRUCTION AREA AND WITHIN THE LIMITS OF CONSTRUCTION.
- FURNISH, ERECT, PLACE AND MAINTAIN TRAFFIC CONTROL SIGNS AND DEVICES. MAINTAIN TRAFFIC DURING HOURS OF CONSTRUCTION AND AT ALL OTHER TIMES CONSISTENT WITH THE METHODS INDICATED ON THESE DRAWINGS AND THE FOLLOWING: PENNDOT PUBLICATION 35; PENNDOT PUBLICATION 46; PENNDOT PUBLICATION 72M; PENNDOT PUBLICATION 111; PENNDOT PUBLICATION 212; PENNDOT PUBLICATION 213; PENNDOT PUBLICATION 236; PENNDOT PUBLICATION 408; AND MUTCD, CURRENT EDITION.
- REMOVE THESE DEVICES IMMEDIATELY UPON COMPLETION OF THE WORK. PENNDOT WILL REMOVE ANY TRAFFIC CONTROL DEVICES ERECTED BY DEPARTMENT FORCES.
- PERMITTEE MUST ARRANGE FOR INSPECTION OF ALL TRAFFIC CONTROL DEVICES PRIOR TO START OF WORK.
- COVER OR REMOVE ALL CONFLICTING SIGNS AND ERADICATE ALL CONFLICTING PAVEMENT MARKINGS.
- MOUNT ALL LONG-TERM ADVANCE WARNING SIGNS ON TYPE III BARRICADES UNLESS OTHERWISE NOTED OR INSTRUCTED BY DISTRICT OFFICE.
- ALL SIGNS AND DEVICES TO BE MAINTAINED IN NEW OR LIKE NEW CONDITION.
- DRIVEWAYS WILL BE KEPT ACCESSIBLE AT ALL TIMES. LOCATE ALL SIGNS SO THAT SIGHT DISTANCES WILL NOT BE OBSTRUCTED AT DRIVEWAYS AND LOCAL ROADS.

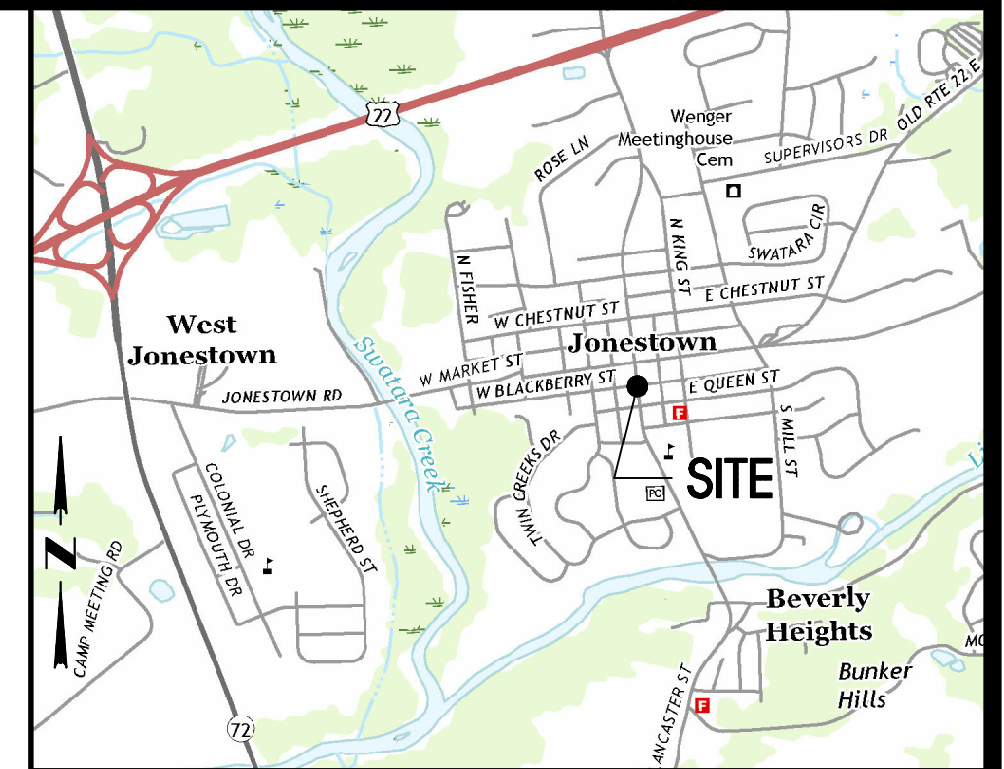

LOCATION MAP

SCALE: 1" = 2000'
2000 1000 0 1000 2000 4000

PENNDOT MAINTENANCE AND PROTECTION OF TRAFFIC (MPT) NOTES (CONT'D):

- ALL CHANNELIZING DEVICES, BARRICADES, AND SIGNS SHALL HAVE TYPE III OR BETTER PRISMATIC RETROREFLECTIVE SHEETING. SHEETING SHALL BE APPROVED AND LISTED IN PENNDOT PUBLICATION 35 (BULLETIN 15).
- NO TRAFFIC RESTRICTIONS OR LANE CLOSURES ARE PERMITTED BETWEEN 6:00 AM AND 9:00 AM AND BETWEEN 3:00 PM AND 6:00 PM MONDAYS THROUGH FRIDAYS OR ON LEGAL HOLIDAYS AND WEEKENDS ASSOCIATED WITH LEGAL HOLIDAYS. ALL RESTRICTIONS AND CLOSURES ARE TO BE REMOVED BY NOON ON THE DAY PRIOR TO THE LEGAL HOLIDAY.
- PERMITTEE SHALL NOTIFY LOCAL EMERGENCY AUTHORITIES (E.G., POLICE, FIRE, MEDICAL), AFFECTED BUSINESSES, SCHOOL DISTRICT(S), THE GENERAL PUBLIC, THE DISTRICT PERMIT MANAGER AND THE DISTRICT APPAS COORDINATOR AT LEAST FOURTEEN DAYS PRIOR TO ANY SIGNIFICANT TRAFFIC IMPACTS (E.G., LATERAL WIDTH RESTRICTIONS LESS THAN 16 FEET, DETOURS).
- MAINTENANCE AND PROTECTION OF TRAFFIC DURING CONSTRUCTION SHALL BE IN ACCORDANCE WITH APPLICABLE PATA DRAWING (S) PATA 101, PATA 102, PATA 103, PATA 107, PATA 110A, PATA 128, PATA 129 IN THE CURRENT PENNDOT PUBLICATION 213, TEMPORARY TRAFFIC CONTROL GUIDELINES.
- DROPOFFS CREATED BY CONSTRUCTION OPERATIONS SHALL BE TREATED CONSISTENT WITH PUBLICATION 408, SECTION 901.3(J).
- REMOVE ALL SHORT-TERM WORK ZONE TRAFFIC CONTROL SIGNING UPON COMPLETION OF THAT DAY'S WORK PERIOD.
- RESTRICTING TRAFFIC FLOW WITHIN THE WORK AREA SHALL BE MINIMIZED TO PREVENT TRAFFIC CONGESTION AND UNSAFE TRAFFIC CONDITIONS.
- NOTIFY THE LOCAL MUNICIPALITY WHERE SIGNALIZED INTERSECTIONS FALL WITHIN THE WORK ZONE. DO NOT FLAG A SIGNALIZED INTERSECTION WITHOUT THE MUNICIPALITY PLACING THE SIGNAL ON FLASH.
- THE CONTRACTOR SHALL COMPLY WITH ACT 229 OF DECEMBER 2002 DURING CONSTRUCTION ACTIVITIES WITHIN PENNDOT'S RIGHT-OF-WAY.

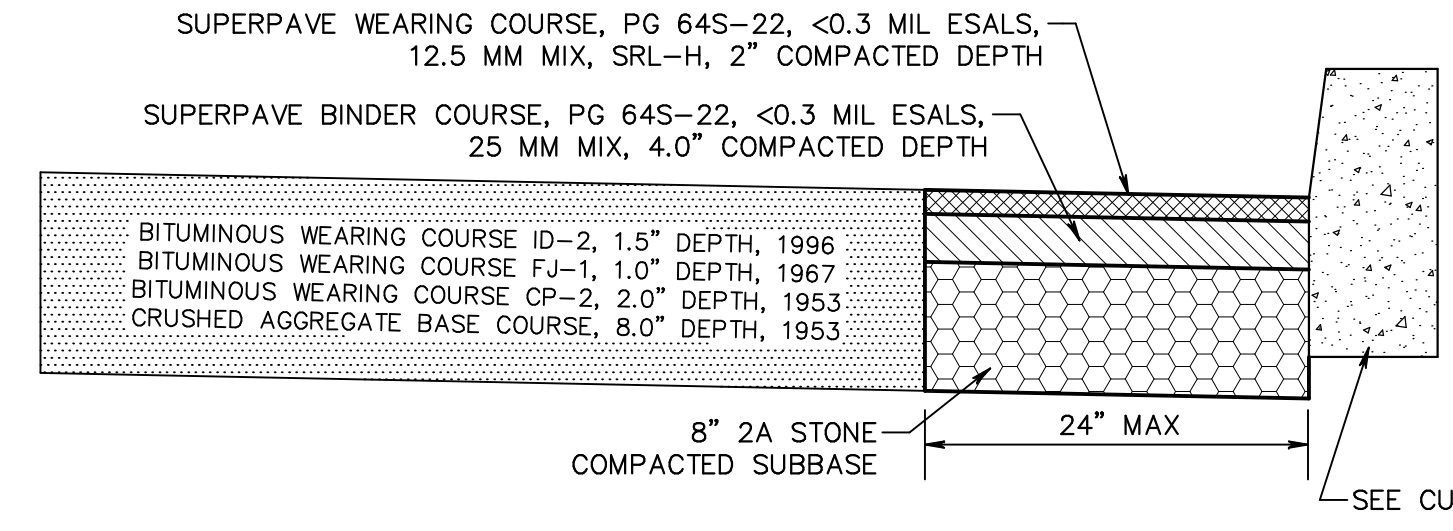

FOR CURB AND SIDEWALK CONSTRUCTION DETAILS & SPECIFICATIONS, REFERENCE PUBS. 72M & 408

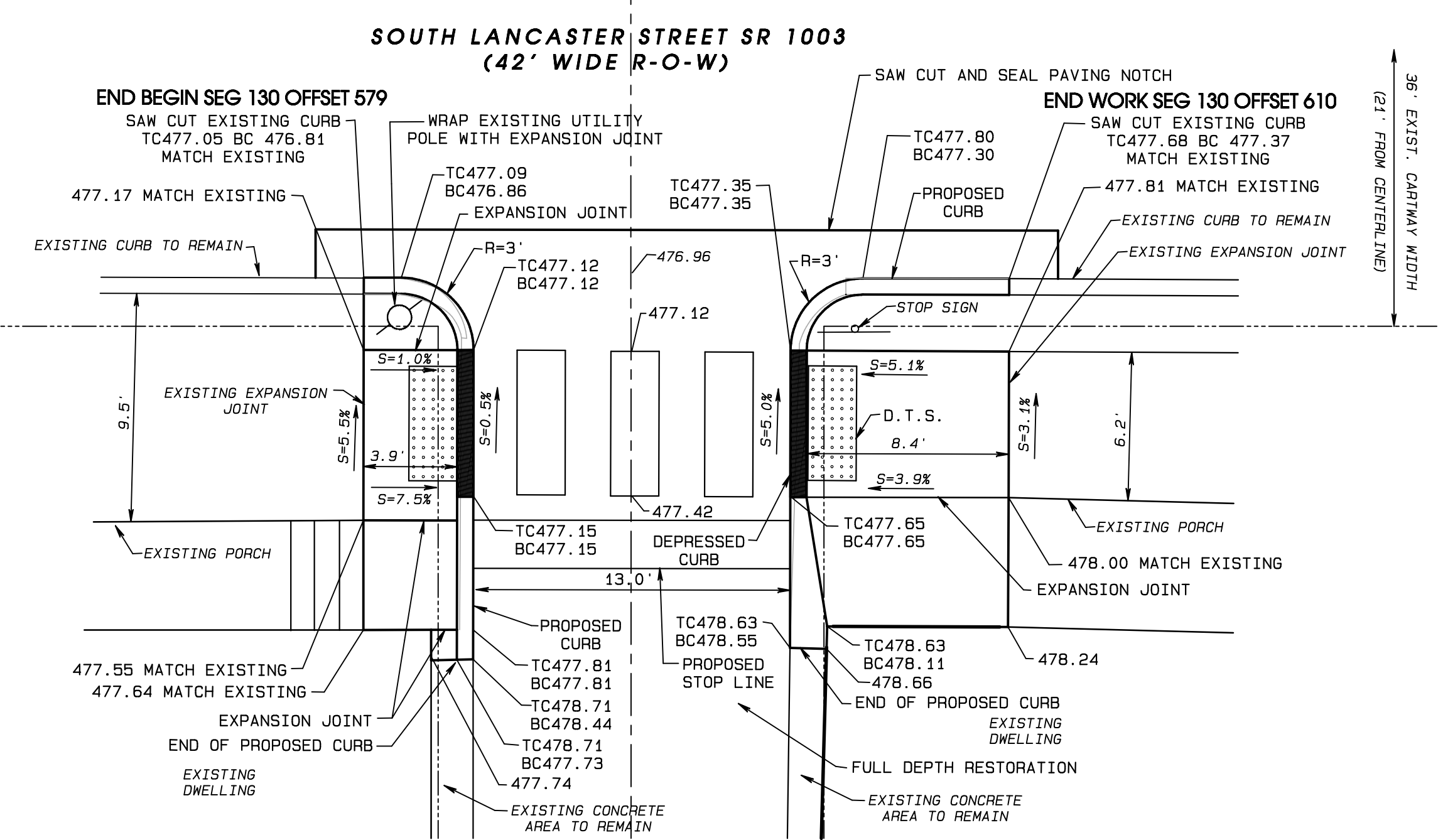

PLAN VIEW EAST BLACKBERRY STREET

SCALE: 1" = 5'

- CERTIFICATION -
ENGINEER

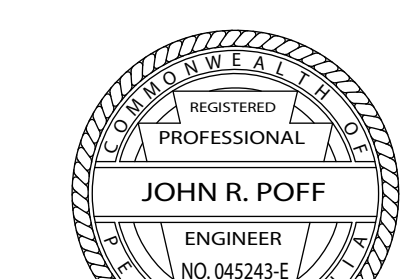

DATE: 3/21/2022

NO.	REVISION	DATE
1	REVISED PAVEMENT SECTION	03/17/2022

CURB & SIDEWALK HOP PLAN

CONSTRUCTION PLANS
FOR
**EAST BLACKBERRY STREET
IMPROVEMENTS PLAN**
LOCATED IN
JONESTOWN BOROUGH, LEBANON COUNTY, PENNSYLVANIA
OWNER
BOROUGH OF JONESTOWN
295 S. MILL ST. PO BOX 446
JONESTOWN, PA 17038
(717) 861-5414

LIGHT-HEIGEL AND ASSOCIATES, INC.
ENGINEERS AND SURVEYORS
430 EAST MAIN STREET, PALMYRA, PA. 17078
(717) 838-1351 FAX (717) 838-3820 1-800-257-2190 www.light-heigel.com

REGIONAL OFFICES
LANCASTER, PA WEST CHESTER, PA LEWISBURG, PA
HALIFAX, PA SCHUYLKILL HAVEN, PA

DATE: 02/03/2022 CHECKED BY: EAH/JRP DWS. NO.: PA00-0091
SCALE: N/A DRAWN BY: EAH MAPCHECK: N/A
COMP'D BY: FIELD: EAH SHEET: 1 OF 1

MBE/WBE DIRECTIONS

Contact Dan Lyons at 717-273-9326 or dlyons@lebanoncountyredevelopment.com for the list of minority and women business entities who *must* be contacted during preparation of your bid to demonstrate compliance and responsiveness.

"General Decision Number: PA20220006 03/11/2022

Superseded General Decision Number: PA20210006

State: Pennsylvania

Construction Types: Heavy and Highway

Counties: Adams, Berks, Bradford, Carbon, Columbia, Cumberland, Dauphin, Juniata, Lackawanna, Lancaster, Lebanon, Lehigh, Luzerne, Lycoming, Monroe, Montour, Northampton, Northumberland, Perry, Pike, Schuylkill, Snyder, Sullivan, Susquehanna, Tioga, Union, Wayne, Wyoming and York Counties in Pennsylvania.

HEAVY AND HIGHWAY CONSTRUCTION PROJECTS (Excluding Sewer Grouting Projects and Excluding Sewage and Water Treatment Plant Projects)

Note: Contracts subject to the Davis-Bacon Act are generally required to pay at least the applicable minimum wage rate required under Executive Order 14026 or Executive Order 13658. Please note that these Executive Orders apply to covered contracts entered into by the federal government that are subject to the Davis-Bacon Act itself, but do not apply to contracts subject only to the Davis-Bacon Related Acts, including those set forth at 29 CFR 5.1(a)(2)-(60).

<p>If the contract is entered into on or after January 30, 2022, or the contract is renewed or extended (e.g., an option is exercised) on or after January 30, 2022:</p>	<ul style="list-style-type: none"> . Executive Order 14026 generally applies to the contract. . The contractor must pay all covered workers at least \$15.00 per hour (or the applicable wage rate listed on this wage determination, if it is higher) for all hours spent performing on the contract in 2022.
<p>If the contract was awarded on or between January 1, 2015 and January 29, 2022, and the contract is not renewed or extended on or after January 30, 2022:</p>	<ul style="list-style-type: none"> . Executive Order 13658 generally applies to the contract. . The contractor must pay all covered workers at least \$11.25 per hour (or the applicable wage rate listed on this wage determination, if it is higher) for all hours spent performing on that contract in 2022.

The applicable Executive Order minimum wage rate will be adjusted annually. If this contract is covered by one of the Executive Orders and a classification considered necessary for performance of work on the contract does not appear on this wage determination, the contractor must still submit a

conformance request.

Additional information on contractor requirements and worker protections under the Executive Orders is available at <https://www.dol.gov/agencies/whd/government-contracts>.

Modification Number	Publication Date
0	01/07/2022
1	01/28/2022
2	02/11/2022
3	02/25/2022
4	03/11/2022

BOIL0013-003 01/01/2022

	Rates	Fringes
BOILERMAKER.....	\$ 50.17	34.96

 CARP0167-006 05/01/2019

BERKS, CARBON and LANCASTER

	Rates	Fringes
CARPENTER.....	\$ 32.07	15.49

 CARP0167-007 05/01/2021

LEHIGH and NORTHAMPTON COUNTIES

	Rates	Fringes
CARPENTER.....	\$ 36.02	26.96

 CARP0219-007 05/01/2021

CARBON (Townships: East Penn, Lower Towamensing, Mahoning, Franklin, Towamensing, Penn Forest. Everything south of Route 903 and east to the Kidder Township Line. Boroughs: Hauto, Nesquehoning, Lansford, Summit Hill, Jim Thorpe, Weissport, Bownmanstown, Palmerton, Lehighton, and Parryville) , LEHIGH AND NORTHAMPTON COUNTIES

	Rates	Fringes
MILLWRIGHT.....	\$ 45.09	31.94

 CARP0441-005 05/01/2021

BERKS, CARBON, LANCASTER, LEHIGH and NORTHAMPTON COUNTIES

	Rates	Fringes
PILEDRIVERMAN.....	\$ 43.73	37.99

 CARP0443-002 05/01/2021

ADAMS, BRADFORD, CARBON (Banks, Lausanne, Lehigh, Packer, Kidder Twps., and part of Penn Forest Township north of Route

903) COLUMBIA, CUMBERLAND, DAUPHIN, JUNIATA, LEBANON, LUZERNE
 (lower part of) MONROE, MONTOUR, NORTHUMBERLAND, PERRY, PIKE,
 SCHUYLKILL, SNYDER, SULLIVAN, SUSQUEHANNA, TIOGA, UNION, WAYNE,
 WYOMING, YORK (New Cumberland Army Depot and Harrisburg State
 Airport) COUNTIES

	Rates	Fringes
MILLWRIGHT.....	\$ 36.08	53.41%+.86

CARP0443-010 05/01/2021		

BERKS and LANCASTER COUNTIES

	Rates	Fringes
MILLWRIGHT.....	\$ 40.00	21.72

CARP2274-003 05/01/2021		

Adams, Bradford, Columbia, Cumberland, Dauphin, Juniata,
 Lackawanna, Lebanon, Luzerne, Lycoming, Monroe, Montour,
 Northumberland, Perry, Pike, Schuylkill, Snyder, Sullivan,
 Susquehanna, Tioga, Union, Wayne, Wyoming and York

	Rates	Fringes
CARPENTER.....	\$ 33.12	17.74
PILEDRIVERMAN.....	\$ 33.12	17.74

ELEC0126-001 05/31/2021		

ADAMS, BERKS, CUMBERLAND, DAUPHIN, JUNIATA, LANCASTER, LEBANON,
 LEHIGH, NORTHAMPTON, PERRY AND YORK COUNTIES

	Rates	Fringes
Line Construction:		
Cable Splicer.....	\$ 49.22	32.25%+11.00
Groundman.....	\$ 29.53	32.25%+11.00
Lineman.....	\$ 49.22	32.25%+11.00
Truck Driver.....	\$ 31.99	32.25%+11.00
Winch Truck Operator.....	\$ 34.45	32.25%+11.00

ELEC1319-001 01/01/2022		

BRADFORD, CARBON, COLUMBIA, LACKAWANNA, LUZERNE, LYCOMING,
 MONROE, MONTOUR, NORTHUMBERLAND, PIKE, SCHUYLKILL, SNYDER,
 SULLIVAN, SUSQUEHANNA, TIOGA, UNION, WAYNE, AND WYOMING COUNTIES

	Rates	Fringes
Line Construction:		
Equipment Operator.....	\$ 60.72	21.91
Groundmen.....	\$ 37.65	13.23
Linemen.....	\$ 60.72	26.41
Truck Driver.....	\$ 39.47	13.36

* ENGI0542-004 05/01/2021

	Rates	Fringes
Power equipment operators: (HIGHWAY CONSTRUCTION AND WATER LINES CONSTRUCTION (OFF PLANT SITE))		
GROUP 1.....	\$ 39.10	24.70
GROUP 1a.....	\$ 41.35	25.38
GROUP 2.....	\$ 37.93	24.35
GROUP 3.....	\$ 37.23	24.15
GROUP 4.....	\$ 36.77	24.03
GROUP 5.....	\$ 36.26	23.88
GROUP 6.....	\$ 39.33	24.77
GROUP 6a.....	\$ 41.58	25.43

BOOM LENGTH PAY:

On all machines with booms, jibs, masts and leads 100 ft. and over, twenty five cents (\$0.25) per hour additional will be paid for each increment of 25 ft. over 100 ft. On machines with booms (including jibs, masts and leads,etc.), 200 ft. and over, two (2) Operating Engineers shall be required.

POWER EQUIPMENT OPERATORS CLASSIFICATIONS

GROUP 1 - Pile drivers, all types of cranes, all types of backhoes, draglines, keystones, all types of shovels, derricks, trench shovels, trenching machines, paver (blacktop and concrete), gradalls, all front end loaders, tandem scrapers, pippin types backhoes, boat captains, batch plant with mixer, drill self contained (drill-master type), CMI Autograde, milling machine, vemeer saw, conveyor loader (euclid type) scraper and tournapulls, bulldozers and tractors, concrete pumps, motor patrols, mechanic welders, log skidder, side boom, bobcat type (with attachments), boring machines including directional boring machines, chipper with boom, hydro ax, machines similar to the above including remote control equipment.

GROUP 1a: Crawler backhoes and Crawler gradalls over one cubic yard factory rating; Hydraulic backhoes over one cubic yard factory rating; All types of cranes 15 ton and over factory rating; Single person operation truck cranes 15 ton and over factory rating; Cherry picker type machinery and equipment 15 ton and over factory rating; Machines similar to above, including remote control equipment; Equipment in this Wage Group that does not require an oiler.

GROUP 2 - Spreaders, asphalt plant engineers, rollers (high grade finishing), machine similar to above, including remote control equipment, and forklifts 20ft and over.

GROUP 3 - Welding machine, well points, compressors, pump heaters, farm tractors, form line graders, ditch witch type trencher, road finishing machines, concrete breaking machines, rollers, miscellaneous equipment operator, seaman pulverizing mixer, power broom, seeding spreader, tireman - (for power equipment) conveyors, loaders other than EUC type, conveyors, driller second class, machines similar to

the above including remote control equipment, and forklift under 20 ft.

GROUP 4 - Fireman and grease truck

GROUP 5 - Oilers and deck hands

GROUP 6 - All machines with booms (including jibs, masts, leads, etc.) 100 ft. and over.

GROUP 6a: All machines with Booms (including Jibs, Masts, Leads, etc.) 100 feet 15 ton and over factory rating; Machines similar to above, including remote control equipment; Equipment in this Wage Group that does not require an oiler.

TOXIC/HAZARDOUS WAST REMOVAL

Add 20 per cent to basic hourly rate for all classifications

 * ENGI0542-022 05/01/2021

	Rates	Fringes
Power equipment operators: (HEAVY CONSTRUCTION:)		
GROUP 1.....	\$ 38.44	27.52+A
GROUP 1a.....	\$ 40.69	28.18+A
GROUP 2.....	\$ 38.16	27.43+A
GROUP 2a.....	\$ 40.41	28.10+A
GROUP 3.....	\$ 35.24	26.57+A
GROUP 4.....	\$ 34.10	26.24+A
GROUP 5.....	\$ 33.65	26.11+A
GROUP 6.....	\$ 32.77	25.85+A
HEAVY CONSTRUCTION:		

FOOTNOTE:

A: PAID HOLIDAYS: New Year's Day, Memorial Day, Independence Day, Labor Day, Thanksgiving Day, and Christmas Day, the employee works the day before and the day after the holiday.

BOOM LENGTH PAY:

On all machines with booms, jibs, masts and leads 100 ft. from ground up, fifty (\$0.50) per hour additional will be paid for each increment of 25 ft. over 100 ft. On cranes with booms (including jibs, masts and leads, etc.) 200 ft. and over, two (2) operators shall be required, no Oilers will be required, with seventy five (\$0.75) in increments of 25 ft.

TOXIC/HAZARDOUS WASTE REMOVAL

Add 20 per cent to basic hourly rate for all classifications

POWER EQUIPMENT OPERATORS CLASSIFICATIONS

GROUP 1: Machines doing hook work, any machine handling machinery, cable spinning machines, helicopters, machines similar to the above, including remote control equipment,

all types of cranes, cableways, and draglines.

GROUP 1a: Machines doing hook work; Machines handling machinery; All types of cranes 15 ton and over factory rating; Cable ways; Draglines 15 ton and over factory rating; High Rail/Burro Crane 15 ton and over factory rating; Rail Loader (Winch Boom Type) 15 ton and over factory rating; Machines similar to above, including remote control equipment; Equipment in this Wage Group that does not require an oiler.

GROUP 2: Backhoes, keystones, shovels, derricks, trench shovels, trenching machines, hoist with two towers, pavers 21E and over, overhead cranes, building hoists (double drum) gradalls, mucking machines in tunnels, front end loaders, tandem scrapers, pippin type backhoes, boat captains, batch plant operators concrete drills, self-contained rotary drills, fork lifts, 20ft, lift and over, scrapers, tournapulls, spreaders, bulldozers and tractors, rollers (high grade finishing), mechanic-welder, motor patrols, concrete pumps, grease truck, bob cat type (all attachments), boring machines including directional boring machines, hydro ax, side boom, vermeer saw, chipper with boom, machines similar to the above including remote control equipment

GROUP 2a: Crawler backhoes and crawler gradalls over one cubic yard factory rating; Hydraulic backhoes over one cubic yard factory rating; Equipment 15 ton and over factory rating; Machines similar to above, including remote control equipment; Equipment in this Wage Group that does not require an oiler.

GROUP 3: Conveyors, building hoist (single drum), high or low pressure boilers, drill operators, well drillers, asphalt plant engineers, ditch witch type trencher, second class driller, forklift truck under 20ft. lift, stump grinder, tireman (for power equipment), machines similar to above including remote control equipment.

GROUP 4: Welding machines, well points, compressors, pumps, heaters, farm tractors, form line graders, road finishing machines, concrete breaking machines, rollers, seaman pulverzing mixer, power boom, seeding spreader, chipper without boom, machines similar to the above including remote control equipment.

GROUP 5: Fireman.

GROUP 6: Oilers and deck hands (personnel boats).

IRON0404-006 07/01/2021

ADAMS, BERKS, CUMBERLAND, DAUPHIN, JUANITA, LANCASTER, LEBANON, LEHIGH, LYCOMING, MONTOUR, NORTHAMPTON, NORTHUMBERLAND, PERRY, SCHUYLKILL, SNYDER, UNION and YORK COUNTIES

	Rates	Fringes
Ironworkers:.....	\$ 34.01	31.13

 IRON0404-017 07/01/2021

BRADFORD, CARBON, COLUMBIA, LACKAWANNA, LUZERNE, MONROE, PIKE,
 SULLIVAN, TIOGA, SUSQUEHANNA, WAYNE and WYOMING COUNTIES

	Rates	Fringes
IRONWORKER.....	\$ 34.01	31.13

 LABO0158-001 05/01/2021

	Rates	Fringes
Laborers:		
GROUP 1.....	\$ 23.21	18.09
GROUP 2.....	\$ 29.83	18.09
GROUP 3.....	\$ 26.82	18.09
GROUP 4.....	\$ 27.17	18.09
GROUP 5.....	\$ 27.84	18.09
GROUP 6.....	\$ 27.26	18.09
GROUP 7.....	\$ 27.55	18.09
GROUP 8.....	\$ 28.03	18.09

LABORERS CLASSIFICATIONS

GROUP 1: Flag person

GROUP 2: Hazardous/Toxic/Asbestos Waste Handler, Lead Paint Handler

GROUP 3: Asphalt tamper, concrete pitman, puddlers, highway guide rail right of way and property fence slab reinforcement placers, Laborers, landscaper, seeders, planters, magazine tenders, laser beam men for pipe laying and paving machines,, railroad trackman, signalman, asphalt rakers, lute or screed man, pneumatic and electric tool operators, jackmammers, paving breakers, concrete saws, whacker vibrator, chainsaw, highway concrete block layers, sheet hammer, pipe layers, Walk Behind Rollers, Walk Behind Trencher

GROUP 4: Caisson-open air below 8 feet, cofferdam open air below 8 feet where excavations for circular caissons and cofferdams 8 ft and below level of natural grade adjacent to starting point, form setters (road) wagon drill diamond point drill, gunite nozzle operators, walk behind rollers and concrete rubbers, blaster.

GROUP 5: Form Setter, Reinforced Steel Placer, Bonding Aligning and Securing and Burning and welding in Conjunction wth Rebar, and Concrete Surfacers.

FREE AIR TUNNELS AND ROCK SHAFTS

GROUP 6: Outside labers in conjunction with tunnels and rock shafts

GROUP 7: Chuck tenders, muckers, nippers, miners, inside laborers

GROUP 8: Miners, drillers, blasters, pneumatic shield operators, lining, spotting and timber workmen, rebar steel placer, bonding and securing, welders, and concrete surfacers

 PAIN0021-026 05/01/2021

ADAMS, CUMBERLAND, DAUPHIN, LANCASTER, PERRY, AND YORK COUNTIES

	Rates	Fringes
Painters:		
Bridge.....	\$ 33.72	16.30
Brush.....	\$ 25.84	16.30
Spray, Sandblast.....	\$ 27.97	16.30

 PAIN0057-021 06/01/2021

JUNIATA COUNTY

	Rates	Fringes
Painters:		
Bridge, Towers.....	\$ 36.25	21.61
Commercial Brush & Roller...	\$ 29.15	21.61
Industrial Brush & Roller...	\$ 34.00	21.61
Spray.....	\$ 29.15	21.61

 PAIN1021-001 05/01/2012

BERKS, CARBON, LEBANON, LEHIGH, NORTHAMPTON, AND MONROE COUNTIES

	Rates	Fringes
Painters:		
Bridge; Brush, Roller.....	\$ 30.85	14.80
Bridge; Spray.....	\$ 31.85	14.80
Brush and Roller.....	\$ 26.55	14.80
Spray and Sandblast.....	\$ 27.55	14.80

 PAIN1021-002 05/01/2009

BRADFORD, COLUMBIA, LACKWANNA, LUZERNE, LYCOMING, MONTOUR, NORTHUMBERLAND, PIKE, SCHUYLKILL, SNYDER, SULLIVAN, SUSQUEHANNA, TIOGA, UNION, WAYNE, WYOMING COUNTIES

	Rates	Fringes
Painters:		
Bridge; Brush, Roller.....	\$ 25.60	12.05
Bridge; Spray.....	\$ 26.60	12.05
Brush and roller.....	\$ 22.75	12.05
Spray, Sandblast.....	\$ 23.75	12.05

 PLAS0592-004 06/01/2021

MONROE COUNTY; (EXCEPT TOBYHANNA DEPOT)

	Rates	Fringes
--	-------	---------

CEMENT MASON/CONCRETE FINISHER...\$ 35.88 13.30

PLAS0592-005 06/01/2021

COLUMBIA COUNTY

Rates Fringes

CEMENT MASON/CONCRETE FINISHER...\$ 35.88 13.30

PLAS0592-017 05/01/2021

Rates Fringes

CEMENT MASON/CONCRETE FINISHER
BERKS (Northeastern part
lying North of a line
starting from the Southern
boundary line of Lehigh
County continuing through
Huffs Church,
Fredericksville, Dryville,
Lyon Station, Kutztown,
Krumsville, and Stoney Run
in Berks County to the
Lehigh County line),
CARBON, LEHIGH,
NORTHAMPTON (Northwest
part including the towns
of Walnutport, Bath, and
Northampton) COUNTIES.....\$ 32.65 23.43

PLAS0592-018 05/01/2021

Rates Fringes

Cement Mason/Concrete Finisher
Adams, Lancaster and York
Counties.....\$ 31.75 21.50

PLASTERER
Adams, Berks (Portions
of), Lancaster, and
Lebanon Counties.....\$ 28.33 20.90

PLAS9592-002 06/01/2021

MONROE COUNTY (TOBYHANNA ARMY DEPOT)

Rates Fringes

CEMENT MASON/CONCRETE FINISHER...\$ 35.88 13.30

* TEAM0229-003 05/01/2021

Rates Fringes

TRUCK DRIVER (ADAMS, BERKS,
CARBON, COLUMBIA, CUMBERLAND,
DAUPHIN, JUNIATA, LACKAWANA,
LANCASTER, LEBANON, LEHIGH,
LUZERNE, LYCOMING, MONROE,
MONTOUR, NORTHAMPTON,

NORTHUMBERLAND, PERRY, PIKE,
SCHUYKILL, SNYDER, SULLIVAN,
SUSQUEHANNA, UNION, WAYNE,
WYOMING, AND YORK COUNTIES)

GROUP 1.....	\$ 37.72	0.00
GROUP 2.....	\$ 37.79	0.00
GROUP 3.....	\$ 38.28	0.00

Truck drivers: (BRADFORD AND
TIOGA COUNTIES)

GROUP 1.....	\$ 22.66	13.46
GROUP 2.....	\$ 22.73	13.46
GROUP 3.....	\$ 23.22	13.46

TRUCK DRIVERS CLASSIFICATIONS

GROUP 1: Flat Bed Truck (Single-Axle), Dump Trucks (Under 10
Yds Single Axle), Stake Body Trck (Single Axle), Dumpster
(Single Axle)

GROUP 2: Dump Truck (Over 10 Yds), Asphalt Distributors,
Transit Mix (Under 5 Yds), Transit Mix (Over 5 Yds.), Flat
or Stake Body (Tandem), Fuel Truck A-Frame/Winch Trucks,
Dry Batch Truck, Truck Mounted Sweeper and Vac Trucks,
Buses, Dumpster (Tandem)

GROUP 3: Euclid-Type, Off Highway Equipment-Back or Double
Bottom Dump Trucks (Over 20 Tons), Straddle Trucks, Pusher,
Articulate Dumped Trucks, Low Boy Trailers, Semi Trailers

Water Tank, Sprinkler Trucks, Winch Trucks and Fuel Trucks
shall be governed by the appropriate classification as
listed above.

WELDERS - Receive rate prescribed for craft performing
operation to which welding is incidental.

=====
Note: Executive Order (EO) 13706, Establishing Paid Sick Leave
for Federal Contractors applies to all contracts subject to the
Davis-Bacon Act for which the contract is awarded (and any
solicitation was issued) on or after January 1, 2017. If this
contract is covered by the EO, the contractor must provide
employees with 1 hour of paid sick leave for every 30 hours
they work, up to 56 hours of paid sick leave each year.
Employees must be permitted to use paid sick leave for their
own illness, injury or other health-related needs, including
preventive care; to assist a family member (or person who is
like family to the employee) who is ill, injured, or has other
health-related needs, including preventive care; or for reasons
resulting from, or to assist a family member (or person who is
like family to the employee) who is a victim of, domestic
violence, sexual assault, or stalking. Additional information
on contractor requirements and worker protections under the EO
is available at
<https://www.dol.gov/agencies/whd/government-contracts>.

Unlisted classifications needed for work not included within
the scope of the classifications listed may be added after
award only as provided in the labor standards contract clauses

(29CFR 5.5 (a) (1) (ii)).

The body of each wage determination lists the classification and wage rates that have been found to be prevailing for the cited type(s) of construction in the area covered by the wage determination. The classifications are listed in alphabetical order of ""identifiers"" that indicate whether the particular rate is a union rate (current union negotiated rate for local), a survey rate (weighted average rate) or a union average rate (weighted union average rate).

Union Rate Identifiers

A four letter classification abbreviation identifier enclosed in dotted lines beginning with characters other than ""SU"" or ""UAVG"" denotes that the union classification and rate were prevailing for that classification in the survey. Example: PLUM0198-005 07/01/2014. PLUM is an abbreviation identifier of the union which prevailed in the survey for this classification, which in this example would be Plumbers. 0198 indicates the local union number or district council number where applicable, i.e., Plumbers Local 0198. The next number, 005 in the example, is an internal number used in processing the wage determination. 07/01/2014 is the effective date of the most current negotiated rate, which in this example is July 1, 2014.

Union prevailing wage rates are updated to reflect all rate changes in the collective bargaining agreement (CBA) governing this classification and rate.

Survey Rate Identifiers

Classifications listed under the ""SU"" identifier indicate that no one rate prevailed for this classification in the survey and the published rate is derived by computing a weighted average rate based on all the rates reported in the survey for that classification. As this weighted average rate includes all rates reported in the survey, it may include both union and non-union rates. Example: SULA2012-007 5/13/2014. SU indicates the rates are survey rates based on a weighted average calculation of rates and are not majority rates. LA indicates the State of Louisiana. 2012 is the year of survey on which these classifications and rates are based. The next number, 007 in the example, is an internal number used in producing the wage determination. 5/13/2014 indicates the survey completion date for the classifications and rates under that identifier.

Survey wage rates are not updated and remain in effect until a new survey is conducted.

Union Average Rate Identifiers

Classification(s) listed under the UAVG identifier indicate that no single majority rate prevailed for those classifications; however, 100% of the data reported for the classifications was union data. EXAMPLE: UAVG-OH-0010 08/29/2014. UAVG indicates that the rate is a weighted union

average rate. OH indicates the state. The next number, 0010 in the example, is an internal number used in producing the wage determination. 08/29/2014 indicates the survey completion date for the classifications and rates under that identifier.

A UAVG rate will be updated once a year, usually in January of each year, to reflect a weighted average of the current negotiated/CBA rate of the union locals from which the rate is based.

WAGE DETERMINATION APPEALS PROCESS

1.) Has there been an initial decision in the matter? This can be:

- * an existing published wage determination
- * a survey underlying a wage determination
- * a Wage and Hour Division letter setting forth a position on a wage determination matter
- * a conformance (additional classification and rate) ruling

On survey related matters, initial contact, including requests for summaries of surveys, should be with the Wage and Hour National Office because National Office has responsibility for the Davis-Bacon survey program. If the response from this initial contact is not satisfactory, then the process described in 2.) and 3.) should be followed.

With regard to any other matter not yet ripe for the formal process described here, initial contact should be with the Branch of Construction Wage Determinations. Write to:

Branch of Construction Wage Determinations
Wage and Hour Division
U.S. Department of Labor
200 Constitution Avenue, N.W.
Washington, DC 20210

2.) If the answer to the question in 1.) is yes, then an interested party (those affected by the action) can request review and reconsideration from the Wage and Hour Administrator (See 29 CFR Part 1.8 and 29 CFR Part 7). Write to:

Wage and Hour Administrator
U.S. Department of Labor
200 Constitution Avenue, N.W.
Washington, DC 20210

The request should be accompanied by a full statement of the interested party's position and by any information (wage payment data, project description, area practice material, etc.) that the requestor considers relevant to the issue.

3.) If the decision of the Administrator is not favorable, an interested party may appeal directly to the Administrative Review Board (formerly the Wage Appeals Board). Write to:

Administrative Review Board

U.S. Department of Labor
200 Constitution Avenue, N.W.
Washington, DC 20210

4.) All decisions by the Administrative Review Board are final.

=====

END OF GENERAL DECISIO"

Bid Submission Packet

**This information must
be included for your bid
to be considered.**

Contractor's Name: _____

Address: _____

Telephone No.: _____

Fax No.: _____

Federal I.D. No.: _____

E-Mail: _____

SAM.GOV UEI #: _____

**PROPOSAL
REDEVELOPMENT AUTHORITY OF
THE COUNTY OF LEBANON
CONTRACT C-5-22-JB
MAY, 2022**

Redevelopment Authority of the
County of Lebanon
137 W. Penn Avenue
Cleona, PA 17042

Gentlemen:

Pursuant to and in compliance with your request inviting Proposals for the general construction of the above project and having carefully examined the contract documents, comprising the drawings, specifications and all other documents bound therewith; together with all addenda or bulletins thereto; and being familiar with the site and various conditions affecting the work; the undersigned hereby offers to furnish all plans, labor, supervision, materials, supplies, equipment and other facilities and things necessary or incidental to the work as required by and in strict accordance with the applicable provisions of the plans and specifications, contract documents, and of all addenda or bulletins issued by the Owner for the following prices:

Lump sum price: \$ _____

\$ _____ 00/100

In submitting this Bid, the Bidder understands that the right is reserved by the Redevelopment Authority of the County of Lebanon to reject any and all Bids. If written notice of the acceptance of this Bid is mailed, telegraphed or delivered to the undersigned within thirty (30) days after the opening thereof, or at any time thereafter before this Bid is withdrawn, the undersigned agrees to execute and deliver an agreement in the prescribed form and furnish the required bonds within ten (10) days after the agreement is presented to him for signature.

1. Security in the sum of _____ Dollars (\$ _____) in the form of _____ is submitted herewith in accordance with the INSTRUCTIONS TO BIDDERS.
2. Attached hereto is an affidavit in proof that the undersigned has not entered into a collusive agreement with any person in respect to this Bid or the submitting of Bids for the contract for which this Bid is submitted.
3. The Bidder certifies that he does not maintain or provide for his employees any segregated facilities at any of his establishments, and that he does not permit his employees to perform their services at any location, under his control, where segregated facilities are maintained. The Bidder certifies further that he will not maintain or provide for his employees any segregated facilities at any of his establishments, and that he will not permit his employees to perform their services at any location under his control where segregated facilities are maintained. The Bidder agrees that a breach of this certification will be a violation of the Equal Opportunity clause in any contract resulting from acceptance of this Bid. As used in this certification, the term "segregated facilities" means any waiting rooms, work areas, rest rooms and washrooms, restaurants and other eating areas, time clocks, locker rooms and other storage or dressing areas, parking lots, drinking fountains, recreation or entertainment areas, transportation, and housing facilities provided for employees which are segregated by explicit directive or are in fact segregated on the basis of race, color, religion, or national origin, because of habit, local custom, or otherwise. The Bidder agrees that (except where he has obtained identical certification from proposed subcontractors for specific time periods) he will obtain identical certification from proposed subcontractors prior to the award of subcontractors exceeding \$10,000 which are not exempt from the provisions of the Equal Opportunity clause, and that he will retain such certifications in his files.
4. The Bidder also agrees to conform to the Pennsylvania Non-Discrimination Clause contained in these bidding documents.

Date: _____

Bidder

Official Address:

By: _____

Title: _____

East Blackberry Street Bid Form
BASE BID

ITEM	QNTY	UNIT	DESCRIPTION	UNIT PRICE	TOTAL PRICE
1	596	CY	Existing Roadway Excavation		
2	80*	CY	Soft & Yielding Subgrade Removal & Replacement		
3	180	Tons	Superpave Wearing Course, 9.5 MM, 1.5" Depth		
4	370	Tons	Superpave Base Course, 25 MM, 3" Depth		
5	3	Tons	Superpave Wearing Course, 12.5 MM, 2" Depth (PennDOT ROW)		
6	5	Tons	Superpave Base Course, 25 MM, 4" Depth (PennDOT ROW)		
7	637	Tons	Compacted 2A Subbase, 6" Depth		
8	154	LF	Milled Paving Notch at Tie-ins (18" wide)		
9	650	LF	Saw-cut at Limits of Full-Depth Paving		
10	15	LF	Crosswalk Line Painting		
11	6	EA	Painted Stop Bars (24" Wide)		
12	788	LF	Seal Pavement Joints at Tie-ins		
13	1	LS	Topsoil & Seeding		
14	2	EA	South Lancaster Street ADA Curb Ramps		
15	1	LS	Mobilization / Demobilization		
16	1	LS	Maintenance & Protection of Traffic Control Devices		

*Price per unit for an undetermined quantity, if deemed necessary during construction

Mulberry Street Bid Form
ALTERNATE BID

ITEM	QNTY	UNIT	DESCRIPTION	UNIT PRICE	TOTAL PRICE
1	78	CY	Existing Roadway Excavation		
2	10*	CY	Soft & Yielding Subgrade Removal & Replacement		
3	30	Tons	Superpave Wearing Course, 9.5 MM, 1.5" Depth		
4	50	Tons	Superpave Base Course, 25 MM, 3" Depth		
5	84	Tons	Compacted 2A Subbase, 6" Depth		
6	120	LF	Milled Paving Notch at Tie-ins (18" wide)		
7	120	LF	Saw-cut at Limits of Full-Depth Paving		
8	16	EA	Painted Stop Bars (24" Wide)		
9	120	LF	Seal Pavement Joints at Tie-ins		
10	1	LS	Topsoil & Seeding		
11	1	LS	Mobilization / Demobilization		
12	1	LS	Maintenance & Protection of Traffic Control Devices		

*Price per unit for an undetermined quantity, if deemed necessary during construction

NONCOLLUSION AFFIDAVIT OF PRIME BIDDER

State of _____)
County of _____) ss.

_____, being first duly sworn, deposes and says that:

- (1) He/she is _____ of _____, the Bidder that has submitted the attached Bid;
- (2) He/she is fully informed respecting the preparation and contents of the attached Bid and of all pertinent circumstances respecting such Bid;
- (3) Such Bid is genuine and is not a collusive or sham Bid;
- (4) Neither the said Bidder nor any of its officers, partners, owners, agents, representatives, employees or parties in interest, including this affiant, has in any way colluded, conspired, connived or agreed, directly or indirectly with any other Bidder, firm or person to submit a collusive or sham Bid in connection with the Contract for which the attached Bid has been submitted or to refrain from bidding in connection with such Contract, or has in any manner, directly or indirectly, sought by agreement or collusion or communication or conference with any other Bidder, firm or person to fix the price or prices in the attached Bid or of any other Bidder, or to fix any overhead, profit or cost element for the Bid prices or the Bid price of any Bidder, or to secure through any collusion, conspiracy, connivance or unlawful agreement any advantage against the Redevelopment Authority of the County of Lebanon or any person interested in the proposed Contract; and
- (5) The price or prices quoted in the attached Bid are fair and proper and are not tainted by any collusion, conspiracy, connivance or unlawful agreement on the part of the Bidder or any of its agents, representatives, owners, employees, or parties in interest, including this affiant.

(Signed) _____

(Title)

Subscribed and sworn to before me this _____ day of _____, 20_____

(Title)

My commission expires _____

BID BOND

KNOW ALL MEN BY THESE PRESENTS, that we the undersigned,

as PRINCIPAL, and _____
as SURETY, are held and firmly bound unto Redevelopment Authority of the County of Lebanon, hereinafter called the "Local Public Agency", in the penal sum of _____ Dollars (\$ _____) lawful money of the United States, for the payment of which sum well and truly to be made, we bind ourselves, our heirs, executors, administrators, successors, and assigns, jointly and severally, firmly by these presents.

THE CONDITION OF THIS OBLIGATION IS SUCH, that whereas the Principal has submitted the accompanying Bid, dated _____, 20 ____, for

NOW, THEREFORE, if the Principal shall not withdraw said Bid within the period specified therein after the opening of the same, or, if no period be specified, within thirty (30) days after the said opening, and shall within the period specified therefore, or if no period be specified, within ten (10) days after the prescribed forms are presented to him for signature, enter into a written Contract with the Local Public Agency in accordance with the Bid as accepted, and give bond with good and sufficient surety or sureties, as may be required, for the faithful performance and proper fulfillment of such Contract; or in the event of the withdrawal of said Bid within the period specified, or the failure to enter into such Contract and give such bond within the time specified, if the Principal shall pay the Local Public Agency the difference between the amount specified in said Bid and the amount for which the Local Public Agency may procure the required work or supplies or both, if the latter be in excess of the former, then the above obligation shall be void and of no effect, otherwise to remain in full force and virtue.

IN WITNESS WHEREOF, the above-bounded parties have executed this instrument under their several seals this ____ day of _____, 20__, the name and corporate seal of each corporate party being hereto affixed and these presents signed by its undersigned representative, pursuant to authority of its governing body.

INDIVIDUAL OR PARTNERSHIP PRINCIPALS

_____(SEAL)
_____(SEAL)
In the presence of: _____(SEAL)
_____(SEAL)

CORPORATE PRINCIPAL

ATTEST: _____
By: _____(SEAL)

SURETY

ATTEST: _____
By: _____(SEAL)

Countersigned:

By: _____
Attorney-in-Fact
State of _____

CERTIFICATE AS TO CORPORATE PRINCIPAL

I, _____, certify that I am the _____
_____, Secretary of the Corporation named as Principal in the within bond; that _____
_____, who signed the said bond on behalf of the Principal was then _____ of
said Corporation; that I know his signature, and his signature thereto is genuine; and that said bond was duly
signed, sealed and attested to for and in behalf of said Corporation by authority of this governing body.

Title: _____

(CORPORATE SEAL)

STATEMENT OF BIDDER'S QUALIFICATIONS

All questions must be answered and the data given must be clear and comprehensive. This statement must be notarized. If necessary, questions may be answered on separate attached sheets. The Bidder may submit any additional information he desires.

1. Name of Bidder.
2. Permanent main office address.
3. When organized.
4. If a corporation, where incorporated.
5. How many years have you been engaged in the contracting business under your present firm or trade name?
6. Contracts on hand: (Schedule these, showing amount of each contract and the appropriate anticipated dates of completion.)

7. General character or work performed by your company.

8. Have you ever failed to complete any work awarded to you?
If so, where and why? (Submit attachment.)

9. Have you ever defaulted on a contract?
If so, where and why? (Submit attachment.)

10. List the more important projects recently completed by your company, stating the approximate cost for each, and the month and year completed. (Submit attachment.)

11. List your major equipment available for this contract.

12. Experience in construction work similar in importance to this project.

13. Background and experience of the principal members of your organization, including the officers.

14. Credit available: \$ _____.

15. Give bank reference: _____

16. Will you, upon request, fill out a detailed financial statement and furnish any other information that may be required by the Redevelopment Authority of the County of Lebanon in verification of the recitals comprising this Statement of Bidder's Qualification?

Dated at _____ this _____ day of _____, 20____.

(Name of Bidder)

By _____

Title _____

State of _____)

County of _____)

_____ being duly sworn deposes and says that he is
_____ of _____

and that the answers to the foregoing questions and all statements therein contained are true and correct.

Subscribed and sworn to before me this _____ day of _____, 20____.

Notary Public

My commission expires _____, 20____

MBE/WBE SECTION 3 CONTRACT SOLICITATION AND COMMITMENT STATEMENT

(1) Name of Bidder	(2) IFB Number C-1-20-SLT-ARRP-2
Address	Bid Opening Date
Telephone Number	Contact Person

(8) NOTE: List those certified minority/women owned businesses from which you solicited quotes or which contacted you and gave you quotes in regard to this invitation for bid. Bidder's contract with Subcontractors and suppliers should be at least five days prior to the bid opening date.

*(3) COMPANY NAME EIN/SSN TELEPHONE NUMBER	(4) MBE (X)	(4) WBE (X)	(4) Sec. 3 (X)	(5) TYPE OF CONSTRUCTION, EQUIPMENT, SERVICES AND/OR SUPPLIES TO BE PROVIDED TO THE PROJECT	(6) TOTAL DOLLAR AMOUNT OF QUOTE RECEIVED	*(7) TOTAL COMMITMENT DOLLAR AMOUNT

(9) NOTE Minimum Levels (MPL): MBE-5%, WBE-3%
 A presumption of responsibility may be made if the dollar commitment of MBE/WBE reflects this minimum participation level.

(10) Prepared By:	Telephone Number/E-mail Address:
-------------------	----------------------------------

Use additional sheets if necessary.

**INSTRUCTIONS FOR COMPLETION OF
THE MBE/WBE SUBCONTRACTOR AND
SUPPLIER SOLICITATION AND COMMITMENT FORM (DCED-CCD-286)**

The purpose of this form is to determine whether the bidder has discriminated in the selection of subcontractors and suppliers.

INSTRUCTIONS FOR BLOCKS 1 AND 2

1. Provide your company name, address, telephone number, fax number, e-mail address and contact person.
2. Provide the contract number, bid opening date, and total amount of the bid. If more than one base bid is submitted, provide the total bid amount for Base Bid #1.

INSTRUCTIONS FOR BLOCKS 3 - 7

3. Enter the official subcontractor or supplier's company name exactly as it appears on the Department of General Services (DGS) list of certified MBEs/WBEs at the DGS website (<http://www.dgs.state.pa.us/>) or Department of Transportation (PennDOT) website (www.dot.state.pa.us). Do not use D/B/A (Doing Business As) name. List the address, zip code, telephone number with area code, and contact person's name.
4. Indicate whether the firm is a DGS certified MBE or WBE. Place a (x) in the appropriate column. If the firm is both a DGS certified MBE and a DGS certified WBE, the bidder will receive credit for the firm as either an MBE or a WBE.
5. Briefly describe the specific type of work to be performed and/or materials to be supplied by the listed DGS certified MBE or WBE. In order to count towards reaching the MPLs, bidders must solicit DGS certified MBEs/WBEs in the areas in which they are certified. For example, if an MBE/WBE is certified for electrical supplies and the bidder lists plumbing supplies, the bidder will not receive credit. Geographical location may not be used as a reason for limiting solicitation.
6. Enter the total dollar (\$) amount of the quote received. If the quote was received in the form of unit prices or hourly rates, a total dollar amount must still be provided. If the subcontractor did not respond to the bidder, the bidder must indicate "No Response." Copies of all MBE/WBE quotes must be submitted with the bid.
7. Enter the total dollar (\$) amount of the contractual commitment made to the listed MBE/WBE. If the bidder does not use the total quote from a MBE/WBE because a lower priced quote was received, the bidder must submit a copy of the lower priced quote with its bid. On partial commitments, the bidder must explain why only a partial commitment was made and must submit a copy of the lower priced quote.

INSTRUCTIONS FOR SUBMISSION OF FORM DCED-CCD-286 AND OTHER DOCUMENTATION

8. The bidder must complete and submit Form DCED-CCD-286 with its bid.
9. The bidder must include with the Form DCED-CCD-286 all solicited and unsolicited quotes received by the bidder from MBEs and WBEs as long as the quotes are within the scope of work.

FURTHER INSTRUCTIONS

10. The bidder's contact with MBE/WBE subcontractors and suppliers should be a minimum of (10) days prior to bid opening date. This will ensure that MBE/WBEs have sufficient time to prepare a quote. Ten days is a guide. However, adequate time must be provided to all subcontractors and suppliers to respond.

If the minimum participation levels (MPLs) for this project are not achieved, you must provide a written explanation explaining the failure to achieve the MPLs for MBEs and/or WBEs. Failure to do so will result in rejection of the bid.

If there are any questions/comments concerning this form, please contact the issuing agency contracting officer. If additional forms are needed, you are permitted to photocopy form.

**THE MINORITY BUSINESS ENTERPRISE PROGRAM IN
CONNECTION WITH SCP PROJECTS
IN COMPLIANCE WITH EXECUTIVE ORDER 11625
AFFIRMATIVE ACTION PLAN FOR UTILIZATION OF MINORITY BUSINESS**

Project Name	Project No.
<u>Redevelopment Authority of the County of Lebanon</u> Developer	 General Contractor

CONTRACTING

Prior to the signing of contracts between the Redevelopment Authority of the County of Lebanon and the General Contractor, the General Contractor shall provide to the Redevelopment Authority of the County of Lebanon a preliminary statement of Minority Business Utilization where known; where not known, such information shall be supplied prior to the signing of any contract between the General Contractor and subcontractor(s).

UTILIZATION OF BUSINESSES

Each General Contractor undertaking work on this project shall assure that, to the greatest extent feasible, contracts for work to be performed in connection with the project are awarded to minority business concerns.

The General Contractor shall, to the greatest extent feasible, utilize minority business concerns for procurement (materials, supplies, services) to be performed in connection with this project. To this end the General Contractor projects a Utilization Goal of \$_____ (5%).

CATEGORY	Amount Available in Dollars	GOAL ALLOCATION Amount Projected in Dollars
A. Minority Contractors	\$_____	\$_____
B. Minority Procurement	\$_____	\$_____

GOOD FAITH EFFORT

The following minority business referral agencies will be contacted: SBA, State OMBE, and others: (List)

This is to certify that _____
will abide by and initiate in all our contracts, to the greatest extent feasible, the requirements of Executive Order 11625.

Signature

Title Date